

**Porta  SIP<sup>®</sup>**  
Media Server



## **Administrator Guide**

## **Copyright Notice & Disclaimers**

Copyright © 2000-2013 PortaOne, Inc. All rights reserved.

**PortaSIP® Media Server Administrator Guide, August 2013  
Maintenance Release 35  
V1.35.03**

Please address your comments and suggestions to: Sales Department,  
PortaOne, Inc. Suite #408, 2963 Glen Drive, Coquitlam BC V3B 2P7  
Canada.

Changes may be made periodically to the information in this publication. The changes will be incorporated in new editions of the guide. The software described in this document is furnished under a license agreement, and may be used or copied only in accordance with the terms thereof. It is against the law to copy the software on any other medium, except as specifically provided for in the license agreement. The licensee may make one copy of the software for backup purposes. No part of this publication may be reproduced, stored in a retrieval system, or transmitted in any form or by any means, electronic, mechanical, photocopied, recorded or otherwise, without the prior written permission of PortaOne, Inc.

The software license and limited warranty for the accompanying products are set forth in the information packet supplied with the product, and are incorporated herein by this reference. If you cannot locate the software license, contact your PortaOne representative for a copy.

All product names mentioned in this manual are for identification purposes only, and are either trademarks or registered trademarks of their respective owners.

## Table of Contents

Preface .....	4
Hardware and Software Requirements .....	5
Installation .....	6
What's New in Maintenance Release 35? .....	6
Important Upgrade Notes .....	6
<b>1. System Concepts.....</b>	<b>8</b>
The Media Server's Role .....	9
The Media Server Components .....	10
The Media Server Performance.....	11
The Media Server Clustering .....	12
Conceptual Elements.....	13
Managing IVR Applications via Web GUI.....	14
Call Scenarios.....	16
Auto-Attendant.....	22
Direct Access to Extension from Auto-Attendant.....	28
Call Queues.....	29
Dial-by-name Directory .....	30
Conferencing .....	31
2nd number service.....	35
Calling via Premium Number.....	37
Supported Services .....	40
<b>2. Appendices .....</b>	<b>44</b>
APPENDIX A. Configuration Parameters for IVR Applications.....	45
APPENDIX B. Balance Announcements .....	70
APPENDIX C. Supported DTMF Methods.....	71
APPENDIX D. Fax Transmission-Supported Codecs .....	71
APPENDIX E. Supported Languages.....	72
APPENDIX F. IVR Flow Diagrams .....	77

## Preface

PortaSIP® consists of the PortaSIP® Switching Server and the PortaSIP® Media Server (formerly PortaUM®). This guide mainly covers the PortaSIP® Media Server; consult the [PortaSIP® Switching Server Administrator Guide](#) for information about the PortaSIP® Switching Server.

This document provides a general overview of the PortaSIP® Media Server (hereinafter referred to as the Media Server), a platform for the delivery of enhanced business and residential communications services. The Media Server provides various IVR applications and handles voice, fax, and regular email messages as objects in a single mailbox, which users can access via a web interface or by telephone.

### Where to get the latest version of this guide

The hard copy of this guide is updated upon major releases only, and does not always contain the latest material on enhancements that occur in-between minor releases. The online copy of this guide is always up-to-date, and integrates the latest changes to the product. You can access the latest copy of this guide at [www.portaone.com/support/documentation/](http://www.portaone.com/support/documentation/)

## Conventions

This publication uses the following conventions:

- Commands and keywords are given in **boldface**



The **exclamation mark** draws your attention to important information or actions.

**NOTE:** Notes contain helpful suggestions about or references to materials not contained in this manual.



**Timesaver** means that you can save time by taking the action described here.



**Tips** provide information that might help you solve a problem.

## Trademarks and Copyrights

PortaBilling®, PortaSIP® and PortaSwitch® are registered trademarks of PortaOne, Inc.

# Hardware and Software Requirements

## Server System Recommendations

- A 64-bit processor (Xeon, Opteron). Additional processors are recommended for networks with a high call volume.
- A minimum of 500 GB of available disk space. On the average, 5,000 voice mailboxes take up about 1 GB of disk space, plus you need to reserve an amount of free space roughly equal to the projected database size for performing operations such as backup. RAID is recommended in order to improve performance and reliability.
- At least 8 GB of RAM, 12 GB recommended.

For additional details and configuration advice, see the *Hardware Recommendations* topic on our website:

<http://www.portaone.com/support/faq/hardware-requirements/hardware-requirements/>

For information about whether particular hardware is supported by Oracle Enterprise Linux from the JumpStart Installation CDs, consult the related document on the Oracle or RedHat website:

<https://hardware.redhat.com/>

## Client System Recommendations

- OS: Windows XP, Vista or 7, UNIX or Mac OS X
- Web browser: Internet Explorer 8.0 (or higher), Mozilla Firefox 3.6 (or higher)
- JavaScript and cookies enabled in web browser
- Display settings:
  - Minimum screen resolution: 1024 x 768

## Installation

Jumpstart installation CDs contain installation media for Oracle Enterprise Linux (64-bit version), supplementary packages necessary for convenient system administration and maintenance, and all required software packages. After the installation is complete you will assign roles (e.g. RADIUS, web interface, PortaSIP®, etc.) to individual servers using the configuration server tool – this will automatically enable the required components of the PortaSIP® Media Server software on each server.

For detailed installation instructions, please refer to the [PortaSwitch Installation Guide](#).

## What's New in Maintenance Release 35?

- **Managing video conferences via OSD-menu / IVR** – Now it is possible to operate video conferences with the help of the OSD-menu and IVR. There are currently two modes for managing video conferences: user and admin. The following options are now available in this menu: mute / unmute one's volume; decrease one's speaking volume; increase one's speaking volume; decrease the conference volume; increase the conference volume. For admin, apart from the above-listed options there are also the following: disconnect the last entered user, enter moderator submenu. The options that are available in the moderator submenu are: mute / unmute all users, announce participants count, eject all users.
- The **PIN Translation Rule** feature was added to the **Prepaid card calling** application. When the **Check Service Password** option is enabled and the **PIN Translation Rule** is set, the IVR application modifies the collected PIN according to the PIN translation rule that allows the use of an ANI-based account (for example, ani442031234567) for PIN authentication. This provides your end-users, normally identified by caller IDs (ANI/CLI), with the option of making calls from other phone numbers without having to input hard-to-remember PIN numbers.

## Important Upgrade Notes

- **Dial-by-name directory redesign** – The dial-by-name functionality was improved and now you can configure

extensions, upload / record extension names, include / exclude certain extensions from being accessible via dial-by-name within a single page on the customer Self-care interface.

# **1 ■ System Concepts**



## The Media Server's Role

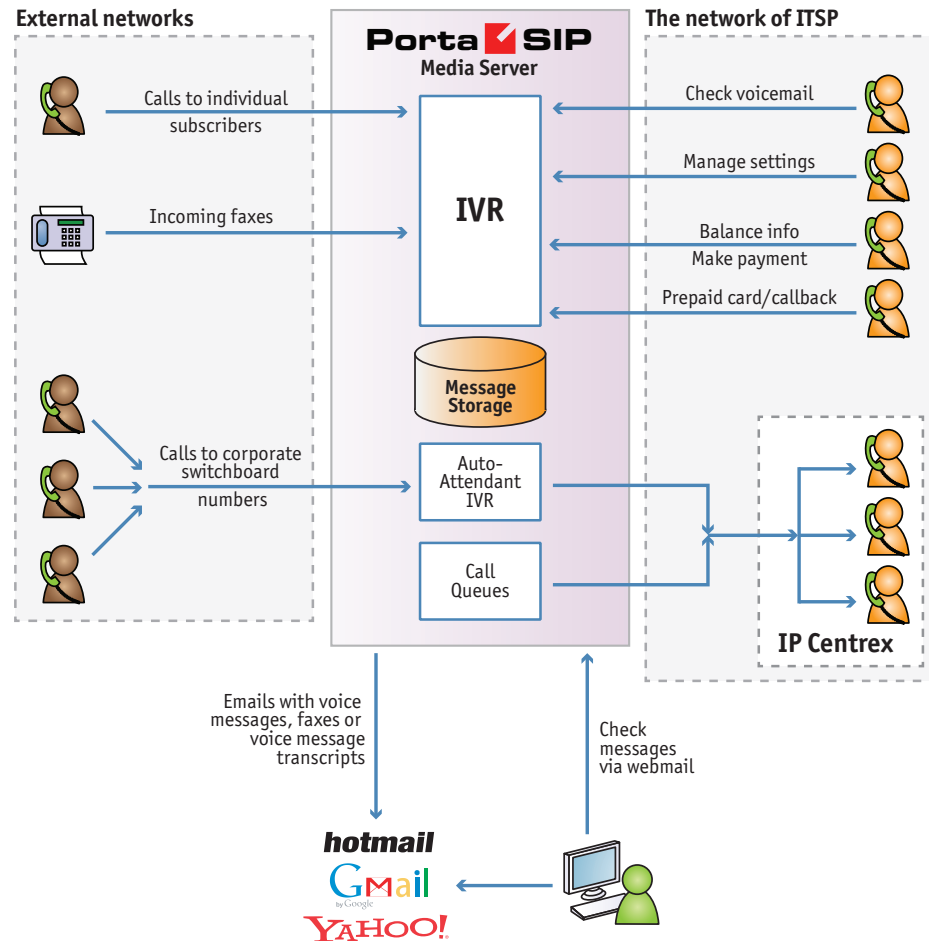

**The Media Server** (Unified Messaging system) is one of the key components of PortaSwitch® – it is a platform which provides users with various IVR applications: balance info, auto-attendant, prepaid card calling, conferencing, voicemail, fax-to-email, and so on.

The Media Server handles voice, fax and regular email messages as objects in a single mailbox, which users can access via a web interface or by telephone.

## The Media Server Components

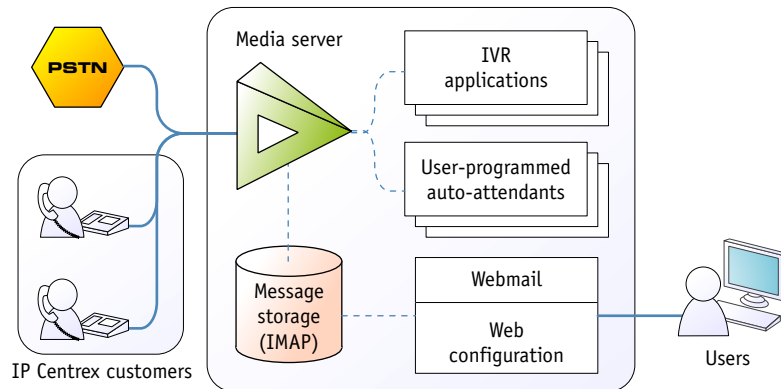

### The Media Server consists of the following main components

- A media server platform that provides IVR (interactive voice response), playing various voice prompts to users and then gathering users' input on the phone dial pad (DTMF) for menu navigation and entry of data such as credit card numbers. This component is also used to record voicemail messages and receive incoming faxes.
- A database server providing storage for all email, voice and fax messages, as well as the user's custom settings and voice prompts.
- An IMAP server which provides a unified interface for message retrieval and management, whether this is done from within the Media Server or by an external application (e.g. the user's Microsoft Outlook client).
- A web server to provide the user with web-based access to his mailbox.
- An SMTP server, used to receive incoming messages from other mail servers, as well as to send outgoing messages created by the user on the web interface, or when a message forwarding service is requested.
- A converter for converting audio and graphic attachments in messages received from the media server into formats compatible with the software available to end-users (e.g. Microsoft Windows operating system).

## The Media Server Architecture

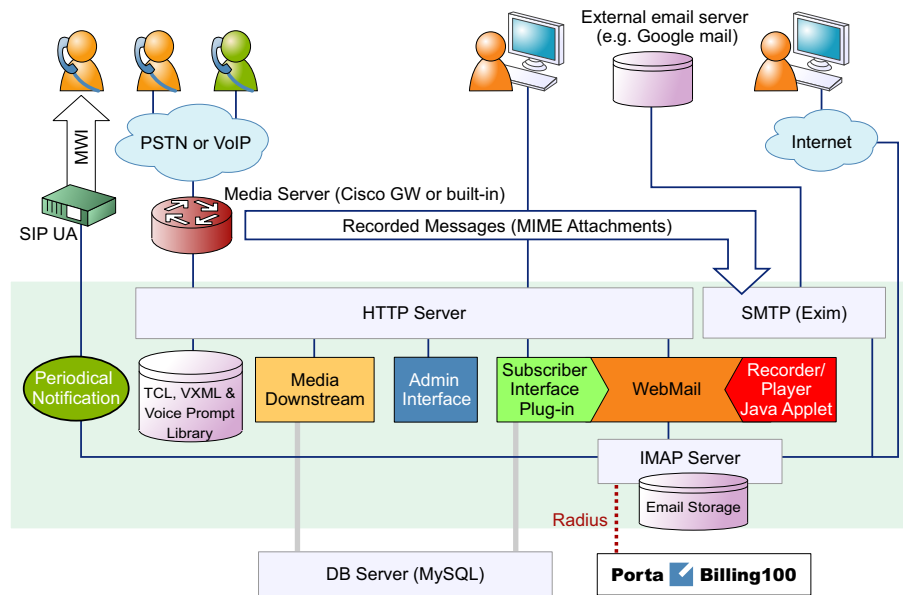

## The Media Server Performance

While for PortaBilling<sup>®</sup> or the Switching Server the majority of resources are used during call initiation or call disconnect, the situation is different with the Media Server. The Media Server provides IVR services, and so all voice traffic must go through it. This means that while a call is in progress, hundreds of RTP packets must be processed each second with minimal delay, in order to maintain acceptable sound quality. This limits the number of concurrent calls a single Media Server can process. (Of course, you can scale up multiple Media Servers to achieve the required performance.)

On a server with the recommended configuration, a Media Server can handle about 1000 incoming IVR sessions (for applications such as auto attendant or balance info), or about 700 concurrent two-way IVR sessions, such as the prepaid card or callback applications, e.g. when there is an incoming call from a user to the Media Server and an outgoing call from the Media Server to an external destination.

Another limitation on the Media Server is the number of mailboxes the server can store. Each mailbox consumes a certain amount of disk space for data storage, and so the total amount of disk space used on the server quickly adds up. For instance, 20,000 users with an average mailbox size of 15 megabytes will require about 300 gigabytes of disk space. You can use quotas to set customers' maximum allowed mailbox size.

## The Media Server Clustering

When multiple Media Servers are installed as part of your PortaSwitch® system, they all connect to the same database which contains IVR application settings, voice mailboxes, auto-attendant menus and all other data required to operate a unified communication service. Thus the function of a media server (playing voice prompts to the user, collecting DTMF input, establishing an outgoing call, etc.) can be performed by any server in the cluster. Incoming calls will be distributed among all of the available Media Servers – this provides the ability to perform load sharing and increase your total IVR capacity. If one of the servers is down because of a hardware failure, the remaining servers will continue processing the call.

To enable quick service recovery on the IVR service in case the database is down – a stand-by database server can be used (similar to the PortaBilling® stand-by configuration).

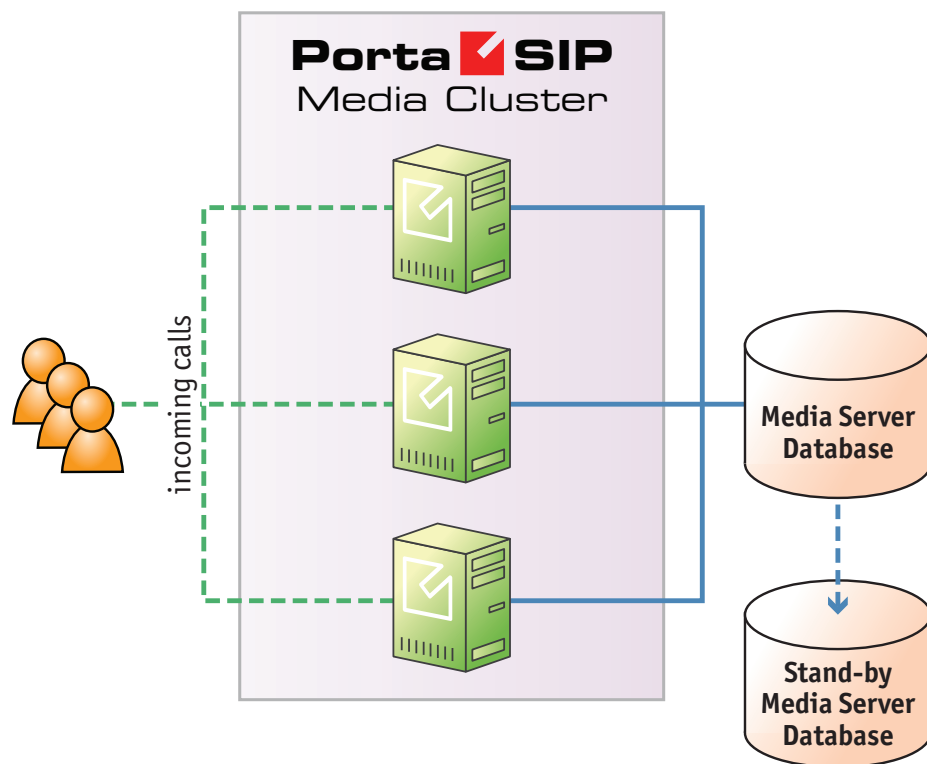

Since the Media Server database contains unified communications data (including voice messages and faxes) for all customers – it may require a significant amount of disk storage space. At the same time, since most Media Server operations include only simple data retrieval, the disk access speed is not crucial. Because of this, if you provide unified messaging services to a large number of customers it is recommended that you avoid running the Media Server database on the same physical server that is

running the PortaBilling® master database – it is better to set up a separate server for this, using larger storage disks. You can potentially even use slower disks (7200 RPM) to reduce the total server cost.

## Conceptual Elements

### Mailbox

A mailbox is a portion of disk space on the Media Server which has been allocated for storing messages. Messages can be voice messages, faxes, or generic emails. You may set a quota (maximum allowed disk space) for user mailboxes, to prevent a situation where some users store too much information in their mailboxes, thus creating problems because the disk space is unavailable for other customers.

### Access Number

When a pre-defined number is dialed from any phone connected to PortaSwitch, or calls to this number are received from an external network – they are forwarded to the Media Server where an IVR application that is associated with this number is launched.

### IVR Applications

When the Media Server answers an incoming call, an IVR (Interactive Voice Response) application is deployed. This application defines how the call is to be further processed, i.e. what the user on the other end will hear. The Media Server IVR applications include, among others:

- Voicemail, allowing callers to leave a message which will be delivered to the user's mailbox;
- Fax-to-email;
- Auto attendant – a custom-designed set of voice menus (see below for more details);
- Check balance / top-up account;
- Prepaid card;
- Conferencing.

Each application normally has a set of parameters which customize its behavior (e.g. whether the prepaid calling card application should announce the available balance or not). The PortaBilling® web interface is used to associate particular applications with a particular access number and then customize the parameters for further applications.

## Auto Attendant

The Media Server’s auto attendant is a flexible utility designed to provide IVR for callers and allow them to navigate among different options by pressing keys on their phones. Auto attendant capabilities include simple features such as playing a certain voice prompt to the end-user or collecting his input, as well as more advanced features such as incoming fax detection or call queues.

## Managing IVR Applications via Web GUI

Using PortaBilling® web interface administrators can quickly and conveniently define how users access IVR applications by dialing phone numbers. Your customers would dial a phone number from the PSTN network or their IP phone to access a specific IVR application; for instance, \*98 for voicemail, 12125551234 to access a prepaid calling card IVR, or 18005559876 to access the audio conferencing facility. So when PortaSwitch® receives a call and matches the destination number with one of the access numbers – the call will be forwarded to the Media Server. The Media Server then will launch the specific IVR application associated with that access number.

Edit	Number *	Name *	Application *	Delete
	16047877722	Conference rooms	Conferencing	X
	*98	*98	One's Own Voice Mailbox Access	X
	18047899001	Local prepaid card access number	Prepaid card calling	X
	18661234555	Toll-free line for calling cards	Prepaid card calling	X
	5555%	IVR announcements	Pass-Through IVR	X

### Application options

The administrator can customize properties of the application that is running on a specific access number.

Edit	Number *	Name *	Application *	Delete
	*98	*98	One's Own Voice Mailbox Access	X
	16047899001	Local prepaid card access number	Prepaid card calling	X
	18661234555	Toll-free line for calling cards	Prepaid card calling	X
	5555%	IVR announcements	Pass-Through IVR	X



Option	Value	Option	Value
ANI Translation Rule		Premium Number SMS Number	
Announce Balance	<input checked="" type="checkbox"/>	Premium Number Deposited Amount	
Announce Time	<input checked="" type="checkbox"/>	Premium Number Currency	
Play Welcome Message	<input type="checkbox"/>	Languages	
Check Service Password	<input type="checkbox"/>	Minimum Voucher Length	11
Minimum Password Length	4	Maximum Voucher Length	11
Maximum Password Length	4	Auto Registration	<input type="checkbox"/>
Prompts Brand		Dynamic Reauthorization	<input type="checkbox"/>
Music on Hold Class	ringtone	Enable Self-Care menu	<input type="checkbox"/>
Check Associated Number	<input type="checkbox"/>	Play an announcement about Self-Care menu	<input type="checkbox"/>
Use Announcement Tariff	<input type="checkbox"/>	Select Outgoing Tariff Based on ANI	<input type="checkbox"/>
Seconds Rounding Mode	none	Auto Registration Without Confirmation	<input type="checkbox"/>
Restriction for Calling with Low Balance	none	Use ANI and Auth Code	<input type="checkbox"/>
ANI Authentication	<input type="checkbox"/>	Auth Code Length	4
End Announce Time, sec	0	Use special access code for first calls	<input type="checkbox"/>
End Announce Type	beep	Use fixed access code for first calls	<input checked="" type="checkbox"/>
Disconn	Choose one of the following types of "time left" warnings: beep - plays "beeping" sound; voice - announces the remaining time in seconds.	Manual Authentication	<input checked="" type="checkbox"/>
Conf La		Minimum Card Length	11
Authoriz		Maximum Card Length	11
Play Pre-ring MOH	<input type="checkbox"/>	Maximum Login Attempts	3
Premium Number Subscribe Command		Maximum Dial Attempts	3

### Distributing incoming IVR calls to specific Media Servers

The administrator can also assign incoming calls on a particular access number to a chosen subset of available Media Servers (PortaUM nodes). The list of available servers – or groups of servers – can be prioritized so calls will first be handled by the server at the top of the list and then in descending order based on availability. A typical case scenario is when Media Servers are installed in multiple geographic locations and it is desirable to handle calls arriving from local telco partners on the Media Servers in a specific region.

Access Number 16047899001  
Voice Application Prepaid card calling

Routing Instance Parameters

Set Routing: Manual

Add Node Add Nodes Pool

Node	Delete
PortaUM - 193.28.85.214(193.28.85.214)	<input type="button" value="X"/>

This will improve call quality by reducing network delay between the telco's originating gateway and the Media Server.

## Call Scenarios

### Call between Subscribers on VoIP Network

In this scenario a subscriber makes a call from his/her IP phone to a phone number that belongs to another subscriber on your VoIP network.

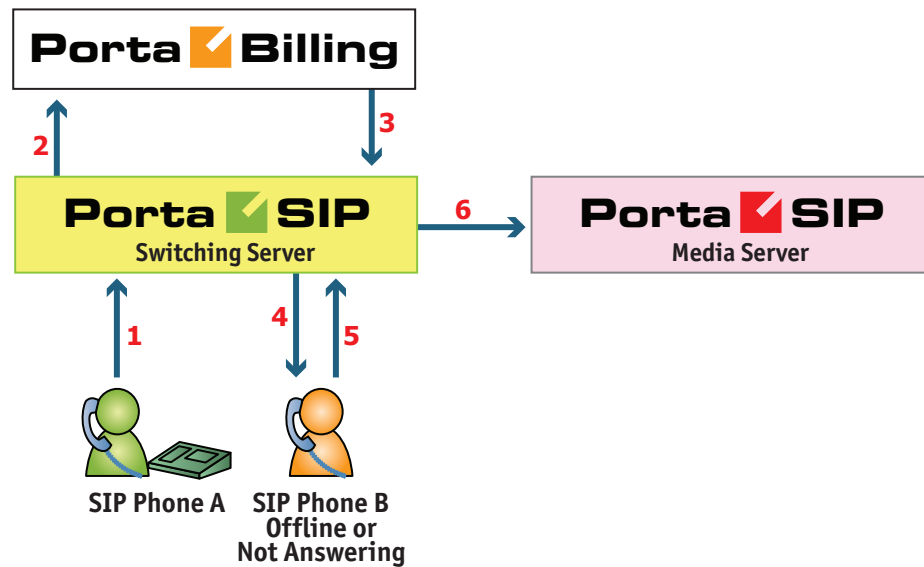

- User A dials 121 in an attempt to reach user B. A's SIP user agent sends an INVITE request to the Switching Server (1).
- The Switching Server performs authorization in the billing (2). For example, if A dialed 121, the billing will inform the Switching Server that the actual number is 12027810009, and that this number belongs to B (3).
- The Switching Server checks the registration database, but it appears that this account is not online at the moment. If B has Unified Messaging services enabled, the call will be redirected to the voicemail system, and A can leave a message for him (6). The same thing would happen if B were online, but did not answer his phone (4), (5).



## A Call from the Outside Network (Via a VoIP DID Provider)

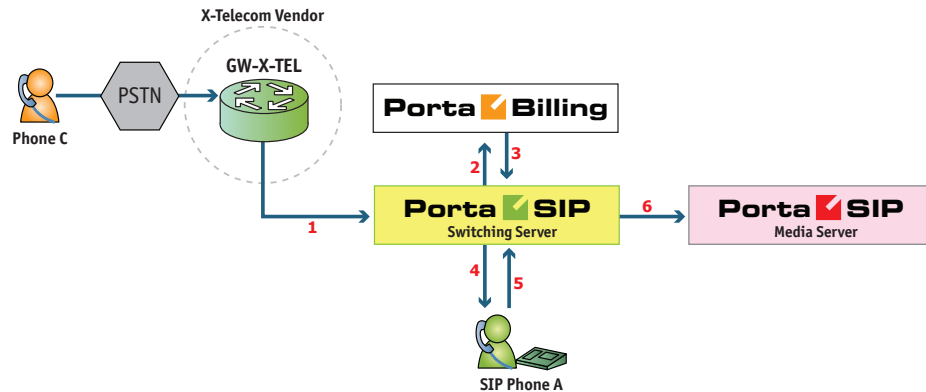

- User C (connected to the phone network of some other telco) wishes to call user A. He dials A's phone number 12025550003.
- The call is routed through the telecom network of the carrier providing the services to C, and then possibly via some transit operators. Eventually the call is delivered to the DID consolidator X-Telecom, which supplies the incoming DID calls to the ITSP. From the switch of the carrier X-Telecom, the call is sent to the Switching Server.
- When an incoming call arrives to the Switching Server (1), after gathering the required information, the Switching Server sends an authorization request to billing (2).
- On the PortaBilling side, several operations are performed:
  - First of all, PortaBilling detects that this is a call coming from a "VoIP from Vendor" connection which belongs to X-Telecom.
  - Then PortaBilling checks whether the number 12025550003 is actually serviced on the ITSP network; this is done to prevent a situation when, either by mistake or intentionally, X-Telecom starts sending transit voice traffic to the ITSP network. Only if there exists an account (or account alias) with ID 12025550003, meaning that this number indeed belongs to one of the customers, will the call be allowed to proceed; otherwise the authorization fails and the call is dropped.
  - Then PortaBilling checks if account 12025550003 is currently listed in the shared database of registered IP phones and what the contact IP address is.
  - Also, since account 12025550003 has the "Unified Messaging" service activated, the Media Server is added to the list of call delivery routes.

- Finally, the authorization confirmation, which includes A's current location (IP address and port), call forwarding or voicemail information and the maximum allowed talk time, is sent back to the Switching Server (3).
- The Switching Server starts the outgoing call to 12025550003 (4).
  - If A answers the call, the call is connected as usual. The Switching Server starts the timer, and will disconnect the call if the maximum call duration is exceeded.
  - If A does not answer his phone (5), or his phone is not registered at this time, then the call is routed to the Media Server.
- The Media Server connects the incoming call (6) and, based on the number called (12025550003), retrieves the configuration settings (language, customized prompts, personal greeting, etc.) for this mailbox.
- The "Voicemail" IVR application is started, which announces that the called party is not available and allows the caller to leave a voice message or send a fax.
- The voice message or fax is processed, converted and delivered to the user's inbox.

## A Call from the Outside Network (Using a Gateway)

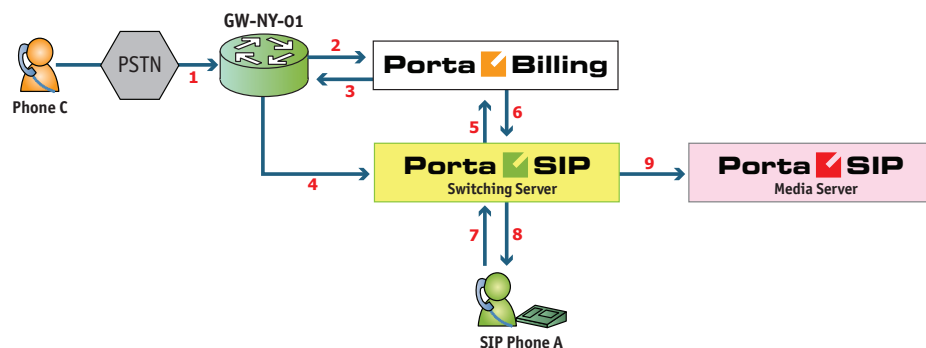

This is an alternative, when calls made on the PSTN network to your numbers are routed to your gateway via the telephony interface.

- User C (connected to the phone network of some other telco) wishes to call user A. He dials A's phone number; since C is in the USA, he dials it in North American format, i.e. 2027810003.
- The call is routed through the telecom network to gateway GW-NY-01. When the incoming call arrives on the gateway (1), it starts a special TCL application to handle this call. This application does several things:

- Converts the phone number to E.164 format, so that 2027810003 becomes 12027810003.
- Performs authorization in the billing (2), i.e. checks whether A is allowed to receive incoming telephony calls from GW-NY-01 and, if you charge for incoming calls, what is the maximum allowed call time based on A's current balance (3). One important point is that authorization must happen without a password check, since the application does not know the valid password for the SIP account.
- Starts the outgoing call to 12027810003.
- When the call is established, it starts the timer, and will disconnect the call if the maximum call duration is exceeded.
- The gateway is configured so that it knows that calls to 1202781.... numbers should be sent to the Switching Server. Thus it sends an INVITE to the Switching Server (4).
- PortaSIP receives the INVITE, but without authorization information. Thus the Switching Server performs authentication based on the IP address (5), (6). Since this call comes from a trusted node, i.e. gateway GW-NY-01, it is authorized.
- The Switching Server checks its registration database, but it appears that this account is not online at the moment. If A has Unified Messaging services enabled, the call will be redirected to the voicemail system, and C can leave a message for him (9). The same thing would happen if A were online, but did not answer his phone (7), (8).

## IVR Application

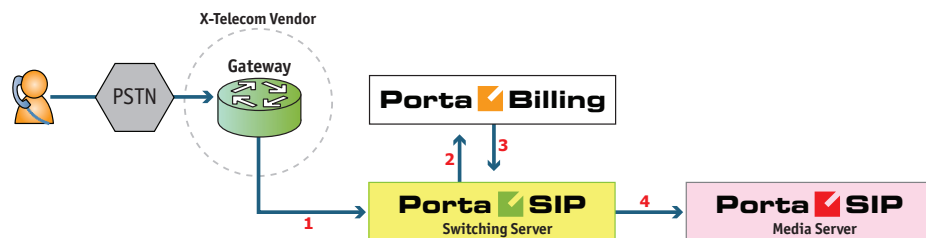

- The service provider wants to allow customers to access an IVR application (e.g. to check their voicemail from an external phone line). The number to be dialed by users (e.g. 18005555865 – 1800-555-5VML) is purchased from the DID provider.
- The administrator creates a new entry in the **Access Numbers** section in PortaBilling, assigning the “Voicemail Access (with PIN protection)” application to 18005555865, and configures the parameters of the application, if necessary.
- Customer C wishes to check his voice messages while out of the office; he dials 18005555865 from his cell phone.

- The call is routed through the telecom network of the cellular carrier providing the services to C, and then possibly via some transit operators. Eventually the call is delivered to the DID consolidator X-Telecom, which supplies incoming DID calls to the ITSP. From X-Telecom's switch the call is sent to the Switching Server.
- When an incoming call arrives to the Switching Server (1), the Switching Server checks the call handling rules to determine how this call should be authorized, i.e. based on the remote IP address or using the username and password. After gathering the required information, the Switching Server sends an authorization request to billing (2).
- On the PortaBilling side, several operations are performed:
  - First of all, PortaBilling detects that this is a call coming from a “VoIP from Vendor” connection which belongs to X-Telecom.
  - Then PortaBilling detects that there is an entry in the Access Numbers section which designates 18005555865 as a special IVR application number.
  - This call will be forwarded to the Media Server, and none of the other call routing options (vendor connections, LCR, etc.) applies in this case.
  - Finally, the authorization confirmation, which includes the routing list (with just the Media Server in it), is sent back to the Switching Server (3).
- The Switching Server routes the call to the Media Server.
- The Media Server connects the incoming call (4) and, based on the number called (18005555865), launches the “Voicemail Access” application.
- The application prompts the user to enter a mailbox ID (his phone number on the VoIP network) and PIN. Upon successful authentication, he can listen to his messages in the same way as he would from his IP phone

## Auto Attendant

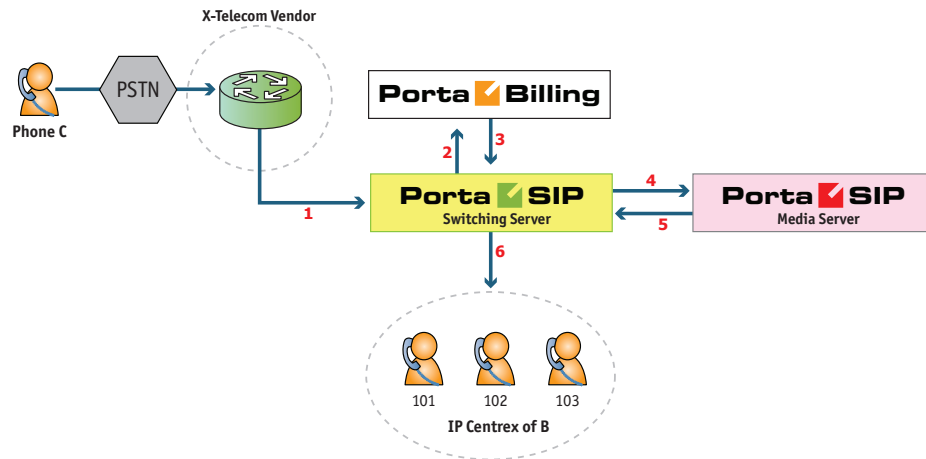

- Customer B, using IP Centrex services, purchases an extra DID number (18005551234) to serve as his main office number. An account with ID 18005551234 is created and the “Unified Messaging” service is enabled for it. This account will not be provisioned on any IP phone, since the goal is to let the Media Server handle the call. The customer logs in to the UM self-care interface and configures the desired menu structure – which announcements should be made, which extensions/huntgroups calls should be forwarded to, etc.
- User C wishes to call company B. He dials B’s phone number 18005551234.
- The call is routed through the telecom network of the carrier providing the services to C, and then possibly via some transit operators. Eventually the call is delivered to the DID consolidator X-Telecom, which supplies the incoming DID calls to the ITSP. From the switch of the carrier X-Telecom, the call is sent to the Switching Server.
- When an incoming call arrives to the Switching Server (1), the Switching Server checks the call handling rules to determine how this call should be authorized, based on the remote IP address or using the username and password. After gathering the required information, the Switching Server sends an authorization request to billing (2).
- On the PortaBilling side, several operations are performed:
  - First of all, PortaBilling detects that this is a call coming from a “VoIP from Vendor” connection which belongs to X-Telecom.
  - Then PortaBilling checks that an account (or account alias) with ID 18005551234 exists, meaning that this number indeed

- belongs to one of the customers; otherwise the authorization fails and the call is dropped.
  - Since the account 18005551234 has the “Unified Messaging” service enabled, and this is not provisioned on any IP phone, the Media Server will be the only entry in the list of call delivery routes.
  - The authorization confirmation including the routing list (containing only the Media Server), is sent back to the Switching Server (3).
- The Switching Server routes the call to the Media Server.
- The Media Server connects the incoming call (4) and, based on the number called (18005551234), retrieves its configuration settings (e.g. auto-attendant activated for this number, voice prompts for menus, etc.).
- The auto-attendant IVR application starts up, plays the menu prompts (e.g. “Welcome to SmartDesign! Please press 1 for sales and 2 for technical support”) and collects the user’s input.
- If, after navigating the menu structure, user C chooses the option of being transferred to one of the extensions in the IP Centrex environment, the Media Server establishes a new outgoing call to the Switching Server (5).
- When an employee answers the call on that extension (6), the Media Server connects this call portion with the incoming call from user C directly, and is not involved in any further processing of this call (thus resources are free to process other calls).

## Auto-Attendant

### Basic Concept

- The Media Server’s auto attendant is composed of a set of menus.
- All the menus are identical in every respect, except for the ROOT menu, which is always present and cannot be deleted, and whose name cannot be changed.
- When a caller dials the system, auto attendant will answer (connect) the call and proceed to the ROOT menu.
- If a user tries to access a menu which is not currently active, the action specified in the **Not Active** configuration parameter will be performed; for instance, the user may be automatically forwarded to an “after hours” menu.
- The **Intro** prompt (e.g. “Welcome to PortaOne, a VoIP solutions company!”) is played when a user enters a menu for the first time.
- After this, the **Menu** prompt will be played, listing all the available options (e.g. “Press 1 for sales, press 2 for technical support”), and

auto attendant will collect the digits dialed by the user on his phone touchpad.

- If no input is received (timeout), the **Default** prompt is played and the dialog reverts to the previous step (i.e. plays the **Menu** prompt and collects the user's input).
- The user's input will be matched with the corresponding menu items, and the action associated with this item will be performed. The following actions are possible:
  - **Default** – Plays the **Default** prompt from the current menu and returns to the “Play **Menu** prompt” step (this is the action used for all menu items where the initial value has not been modified).
  - **Transfer** – Transfers the call to a given telephone number or extension. The phone number should be entered in the same format as the customer would use to dial it from an IP phone in his IP Centrex environment; for example, to transfer a call to extension 123, simply enter 123.
  - **Transfer to E.164 Number** – Transfers the call to a given number. The number should be specified in E.164 format: the country code, followed by the area code, and then the number (e.g. 16045551234 for Canada).
  - **Transfer to Extension** – Transfers the call to an extension number entered by the caller from his phone. To prevent abuse (e.g. someone attempting to enter a long-distance number in this way), you can specify the maximum allowed number of digits in an extension (**Max Size**).
  - **Transfer to Voicemail** – Switches to voicemail mode. This should be designated as an action for the “Fax” event, in order to allow storage of received faxes.
  - **Menu** – Transfers the user to the selected menu.
  - **Directory** – Launches this company's dial-by-name directory.
  - **Queue** – Transfers the call to the specified call queue.
- You may select whether the corresponding **Before Action** prompt is to be played prior to the action.
- A call menu flow chart is shown in the diagram below.

## Call Menu Flow Chart

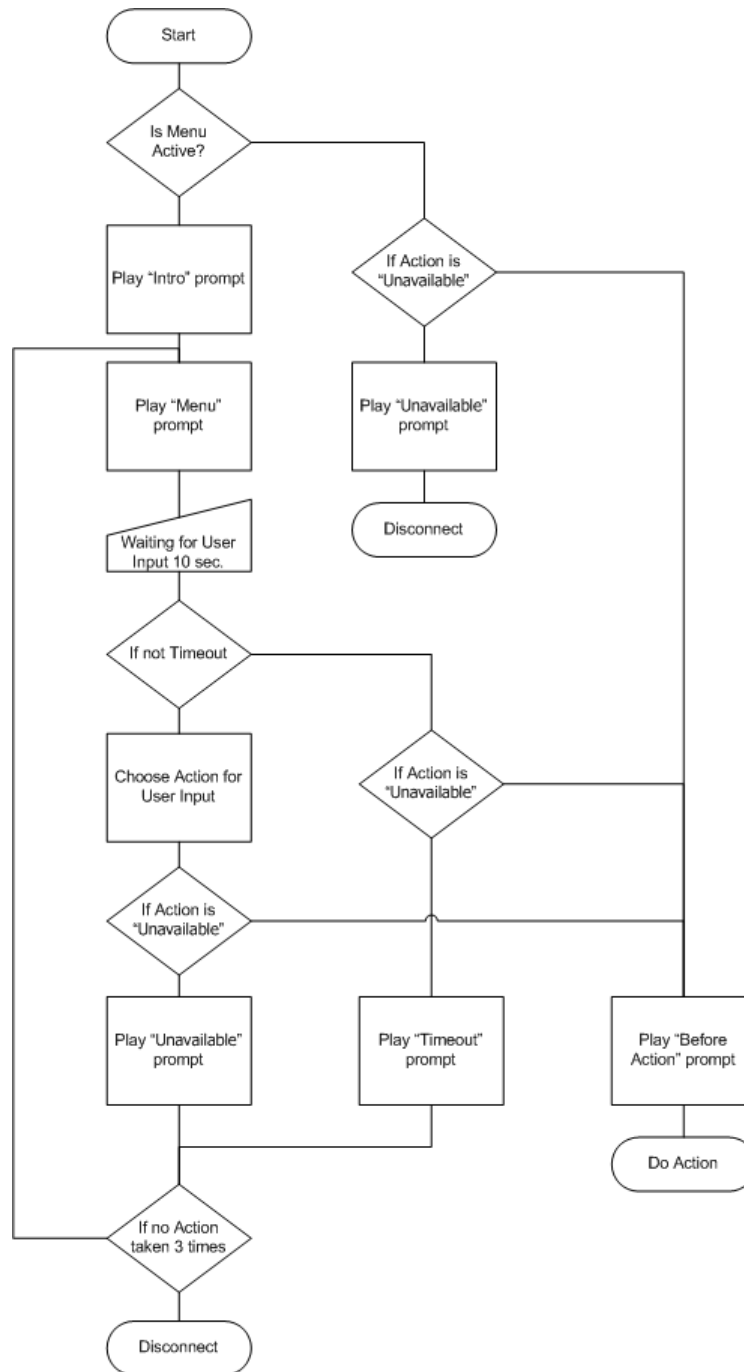

## Menu List Mode

Auto attendant can be selected from the Options menu. The main screen lists all the menus available in the system.



To modify one of the existing menus, select its name from the list.  
To add a new menu, select **+ Add** from the action panel.

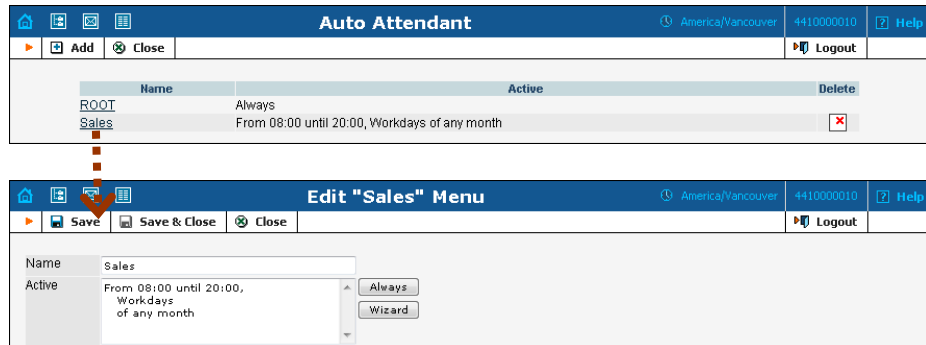

## Menu Edit Mode

After selecting one of the existing menus, please allow all the prompts to load in your browser; this may be viewed on the status indicator in the action pane.

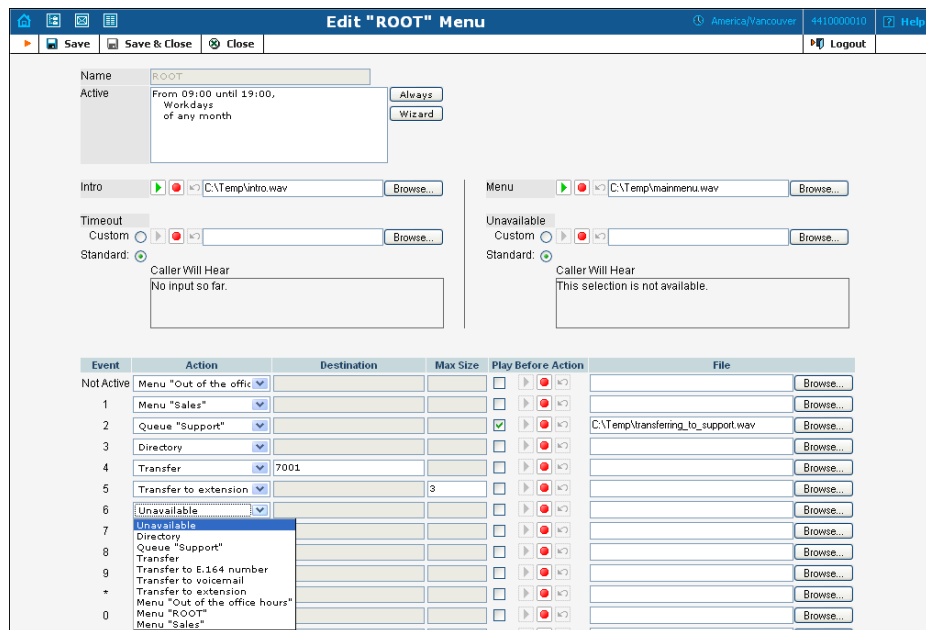

The fields of the Menu Edit screen are explained below:

### Name

A logical name for the menu, i.e. **Sales** for a sales department.

### Active

Time definition for when the current menu is active. To set the menu as always active, select the **Always** button on the right. The Media Server

also provides users with a Period Wizard, a flexible tool for defining a time period of any complexity.

### Period Definition Wizard

Via a series of screens, the user may select a time interval, day of the week, day of the month, and month; multiple selections are allowed.

The following example shows how to create a period starting at 6 pm every day and lasting until 6 am the next morning. Another interval is used on weekends. We will also include some holidays, e.g. January 1 and December 24-26.

In the first screen, select 6 pm in the **From** column and 6 am in the **Until** column. Now select the **Next** button. The two text areas on the right side of the screen provide the user with a display of the current period definition. The top text area displays a verbal definition of the period: From 6:00pm until 6:00am, while the bottom one contains the same information in a format which can be parsed by PortaBilling: `hr { 6pm-5am }`. This sets up the first period; in order to continue, skip the following screens by pressing the **Skip** or **Next** button, until the **Period definition completed** message is displayed. Click **Add** to create another period definition, and the wizard will return to the first screen.

Now for weekends: by pressing the **Skip** or **Next** button, go to the second screen and select *Weekend*, or hold the <Ctrl> key and select *Saturday* and *Sunday* from the list. Now use the **Next** button, skipping forward until the **Period definition completed** message is displayed. Click **Add** to create another period definition.

To include January 1st in the period definition, skip to the Day of the Month screen and select *1*. Now click the **Next** button. Select *January* and click **Next**, skipping forward until the **Period definition completed** message is displayed. Follow the same steps to select the December 24-26 interval. Hold the <Ctrl> key to select multiple entries.

To review your work, look at the top text area. The following should be displayed:



```
From 6:00pm until 6:00am
    any day of any month
OR Sunday and Saturday
    of any month
OR 1
    of January
OR 24-26
    of December
```

If the definition is correct, select **Finish**.



### Intro, Menu, Timeout, Unavailable

You can define four separate prompts (see previous section for an explanation of when each particular type of prompt is played). While you will need to provide content for the **Intro** and **Menu** prompts, you can use the default content for the **Timeout** and **Unavailable** prompts.

 - **Record**. Select to start recording your voice prompt. (You will need to connect a microphone to your computer's sound card to use this feature.)

After the existing prompt has been recorded over, the  **Undo** icon becomes available, allowing rollback to the previous state. The blinking  **Play** icon indicates that the existing prompt is being overwritten, but changes have not been saved yet.

 - **Stop**. Select this to stop recording or playback of the recorded message.

 - **Play**. Select this to play back the recorded prompt. When selected, this icon will turn into  - **Pause**.

Each of the icons above may appear in grayscale, meaning it cannot be accessed because some other task is active.

To give your auto attendant a professional sound, we recommend using a professional speaker and a digital recording studio when recording voice prompts.

To upload a prompt, select the **Browse...** button on the right side. The native audio file format for the system is the following:

**Type:** NeXT/Sun (Java) file .au  
**Format:** G.711 u-Law  
**Attributes:** 8,000 Hz, 8-bit, Mono

The Media Server uses **SOX - Sound eXchange**, a universal sound sample translator for prompts uploaded into native server formats.

Here is a short list of supported audio file formats:

Type	Description
.aiff	AIFF files used on Apple IIc/IIgs and SGI.
.au	SUN Microsystems AU files.
.gsm	GSM 06.10 Lossy Speech Compression
.mp3	MP3 Compressed Audio
.ogg	Ogg Vorbis Compressed Audio.
.raw	Raw files (no header).
.wav	Microsoft .WAV RIFF files.

### Event table

Column	Description
Event	<p><b>Not Active</b> – When the current menu is not active (see the period definition wizard above).</p> <p><b>0-9, #, *</b> – User selection on telephone keypad.</p> <p><b>Timeout</b> – No selection received from user.</p> <p><b>Fax</b> – Fax CNG tone detected.</p>
Action	See the description of available actions in the Basic Concept section above.
Play Before Action	Check this box if the corresponding prompt is to be played before an action is performed.
File	File name and path for the prompt file.

## Direct Access to Extension from Auto-Attendant

In addition to the existing mode that requires an end-user to select a “Dial extension” action first, you may set up direct dialing for the extension from the Auto Attendant. For example, when a customer wants to contact a personal manager, he dials the company’s corporate number (e.g. 18005559876) and the manager’s extension (e.g. 301, found on the manager’s business card). The customer dials 18005559876 from his mobile and reaches the corporate menu, which offers to initiate a call with, e.g. sales by pressing “1,” or the support dept. by pressing “2” or by directly dialing the extension. The customer may now dial “301” without having to listen to all of the options and the call to his manager will be immediately initiated. If the manager is unavailable, the call may be redirected to voicemail (if such an option is activated).

To configure the Direct Access to Extension from Auto-Attendant, follow the steps below:

1. Create the required extension (for example, 301 for account 8002204902).

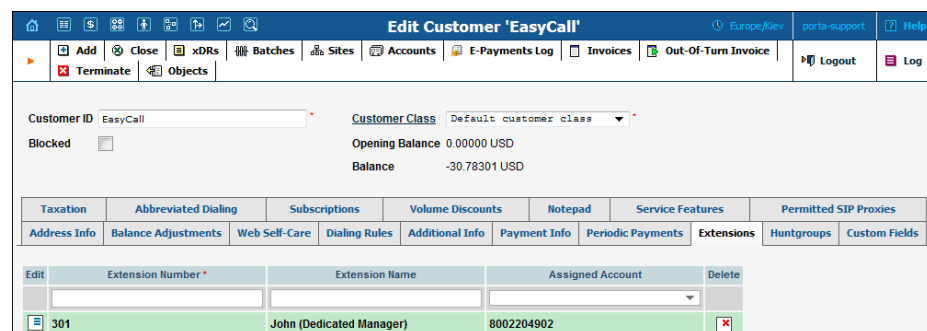

2. Set up the Auto-Attendant option for a number (for example, 8002204900).
3. Add the action “Dial extension directly” for event 3.

The screenshot shows the 'Add Menu' configuration page. The 'Name' field is set to 'Corporate Number'. The 'Active' section has 'Always' and 'Wizard' buttons. The 'Intro' section has 'Custom' and 'None' radio buttons, with 'None' selected. The 'Timeout' section has 'Custom' and 'Standard' radio buttons, with 'Standard' selected. The 'Menu' section has 'Custom' and 'None' radio buttons, with 'None' selected. The 'Unavailable' section has 'Custom' and 'Standard' radio buttons, with 'Standard' selected. The 'Caller Will Hear' field contains 'No input so far.'. Below these settings is a table with the following data:

Event	Action	Destination	Max Size	Play Before Action	File
Not Active	Unavailable			<input type="checkbox"/>	
1	Unavailable			<input type="checkbox"/>	
2	Unavailable			<input type="checkbox"/>	
3	Dial extension directly			<input type="checkbox"/>	
4	Unavailable			<input type="checkbox"/>	
5	Unavailable			<input type="checkbox"/>	
6	Unavailable			<input type="checkbox"/>	
7	Unavailable			<input type="checkbox"/>	

4. When calling 8002204900 and pressing 301, the call will be immediately redirected to John (8002204902).

**NOTE:** The feature is feasible when an extension number starts with the same digit as the “Dial extension directly” option (e.g. 3). Dial 301 but not 3-301, otherwise the extension won't be found.

## Call Queues

This feature allows you to provide a “call center” functionality to your IP Centrex customers. When a large number of incoming calls from customers arrive to the auto attendant, PortaSIP® can forward these calls to the actual agents (customer service representatives) in a regulated fashion.

Every call queue contains several configuration parameters:

The screenshot shows the 'Call Queues' configuration page. It features a table with the following data:

Edit	Queue Name *	Destination *	Max. Connected Calls *	Call Duration *	Music On Hold	Delete
	Sales	12350	1	300	Transferring_to_Sales.wav	
	Support	12345	3	100		

- **Destination** – A phone number where an outgoing call may be forwarded to. The fact that this is a single number does not, of course, mean that you can only have one agent answering calls. This is simply the number used to forward calls to the Switching Server. On the Switching Server side, you can use the call forwarding feature to direct an incoming call to multiple IP phones. Or, alternatively, you may forward this call to an external IP PBX or a gateway with multiple FXS ports; then “hunting” for an available agent will be done on that side.
- **Max Connected Calls** – This defines the “bottleneck” of your queue, i.e. the maximum number of concurrently connected outgoing calls.
- **Call Duration** – The average expected processing time for each call (used to calculate the estimated waiting time).
- **Music on Hold** – A melody (or announcement) which is played to users waiting to be connected.

Each call queue contains a pool of incoming calls (users trying to get connected) and a number of connected outgoing calls (calls that have already been connected to agents). When a new incoming call arrives, it is assigned a position in the queue. The caller will hear an announcement about his position in the queue and the estimated waiting time, which is calculated as  $(\text{average call duration}) / (\text{maximum number of connected calls}) * (\text{total number of users before him in the queue})$ . After that, the specified “music on hold” is played, and every minute the caller is updated as to his current position in the queue and the estimated waiting time.

If there are callers on hold and the number of connected outgoing calls is lower than the specified threshold, the Media Server will attempt to connect the first person in the queue. A call invitation is sent to the destination number in the Switching Server, and the Media Server waits until the call is answered by the other side. If the call is not connected on the first attempt (some representatives may not be available at the moment), the Media Server will make another attempt, then another one, and so on. This will continue until either all of the incoming calls are connected, or the maximum threshold for outgoing calls is reached. In the latter case, the Media Server will simply wait until one of the agents finishes serving his current customer, thereby disconnecting one call and making “room” for a new outgoing call.

## Dial-by-name Directory

This is another element of the auto attendant IVR functionality. If a caller does not know the extension number of the person he is trying to reach, he may look up the called party using the first three letters of his surname.

	Edit	Configure	Extension Number	Extension Name	Assigned To Phone Line	Contact Name	Published	Recorded Name	Delete
General									
Extensions			154	Bob Davies	442369852154		<input checked="" type="checkbox"/>	Not Set	✖
Sites			222	Patrick Wilson	442369852222		<input type="checkbox"/>	Not Set	✖
Phone Lines			267	John Doe	442368463267		<input checked="" type="checkbox"/>	Not Set	✖
External Numbers			775	Michael Turner	442369852775		<input checked="" type="checkbox"/>	Not Set	✖
Dialing Rules									
Incoming Calls									
Outgoing Calls									
Call Recording									
Huntgroups									
Identity									
Music On Hold									

There is a single, unified dial-by-name directory for each IP Centrex environment. Basically it is linked to the list of extensions, and so when creating an extension you can mark it as “published” so that it is included in the dial-by-name directory, and upload voice prompts with the person’s name. You may also exclude certain extensions from being accessible via dial-by-name (e.g. you do not want tele-marketers to directly reach your CEO or CFO because their names are publicly accessible).

The dial-by-name directory can be assigned as an “action” item to any element in the ROOT menu or sub-menu. When a user reaches the dial-by-name dialog, he will be prompted to enter the three first letters in the called party’s surname. Standard phone mapping is used, i.e. 2 is ABC, 3 is DEF, and so on. If no matching person is found, the user is informed of this, and may then re-enter the name or press \* to exit. If more than one match is found (e.g. there are two persons with the “same” surname in the company, e.g. 276 will match both Brown and Asok), the user will hear a list of matching names and their extensions, and may then enter the correct extension.

## Conferencing

### Conferencing Server Architecture

As part of the PortaSIP® solution, the conferencing server enables your customers to use voice-conferencing services. Multiple customers can use this service simultaneously on a single server, and each of them will have access to his own set of virtual conference rooms. The customer can manage his conferences (virtual conference rooms) via the UM self-care interface.

A conference can be scheduled for a specific time, or a continually functioning conference (meeting room) can be created. Each conference is identified by a pair of unique access codes (one for the conference host, the other for conference guests). Although multiple conferences can be created on a Media Server, its resources are only used when a conference is in progress (i.e. at least one participant is in).

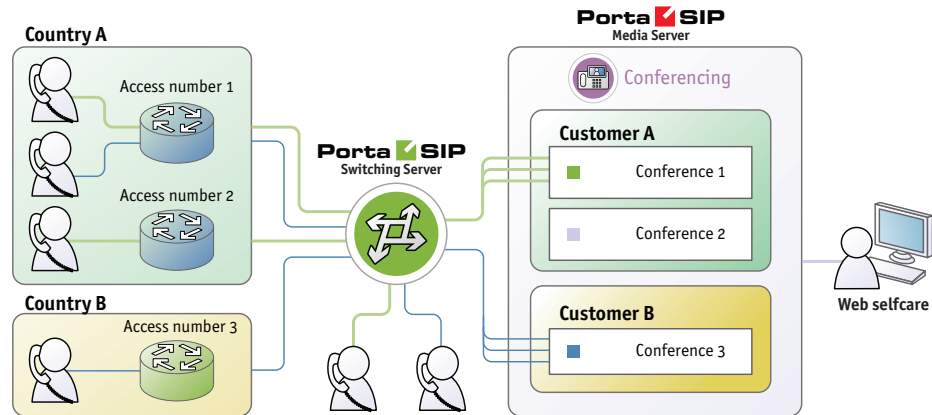

When a customer makes use of the conferencing facility, the PortaBilling® administrator assigns a separate tariff for the conferencing service in the customer’s product configuration, and the owner of the meeting room is then billed for each incoming call in a conference session. For example, if your conference rate is \$0.03/min, and a customer organizes a conference for two participants where he (the host) stays connected for 30 minutes and his two partners stay connected for 25 and 20 minutes, respectively, then there will be three charge transactions in total: \$0.90, \$0.75 and \$0.60. To prevent potential service abuse by guests, customers may create a moderated conference. In this case, guests can only participate in a conference when the host has already joined it.

Conferencing server carries out intensive calculations when mixing the audio from several meeting participants, and so requires significant amounts of CPU power. This is why, if you plan to use the conferencing service extensively, you should consider allocating an additional Media Server just for running the conferencing service, so that your other IVR services (voicemail, auto-attendant, self-care, etc.) can run properly.



## Call Flow

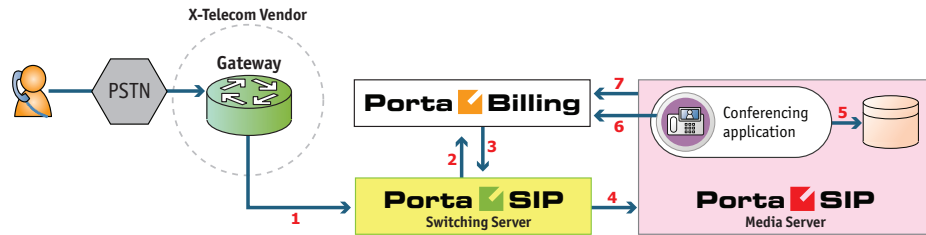

- The service provider wants to allow customers to access the audio conferencing service. The number to be dialed by users (e.g. 18665552637 – 1866-555-CNFR) is purchased from the DID provider.
- The administrator creates a new entry in the Access Numbers section in PortaBilling, assigning the “Conferencing” application to 18665552637, and configures the parameters of the application, if necessary.
- When a customer signs up for the conference service, an account conf1234 for managing the service is created in PortaBilling® and provided to the customer. The customer then logs into their UM self-care interface and creates specific conferences (virtual meeting rooms).
- The customer distributes the conference access information (access phone number and access code) to intended participants of the conference.
- A participant (connected to a network of some other telco) wishes to join the conference; he dials 18665552637 from his cell phone.
- The call is routed through the telecom network of the cellular carrier providing the services to the participant, and then possibly via some transit operators. Eventually the call is delivered to the DID consolidator X-Telecom, which supplies incoming DID calls to the ITSP. From X-Telecom's switch the call is sent to the Switching Server.
- When an incoming call arrives to the Switching Server (1), the Switching Server checks the call handling rules to determine how this call should be authorized, i.e. based on the remote IP address or using the username and password. After gathering the required information, the Switching Server sends an authorization request to billing (2).
- PortaBilling® detects that there is an entry in the **Access Numbers** section which designates 18665552637 as a special IVR application number. The authorization confirmation, including the routing list (containing only the Media Server), is sent back to the Switching Server (3). The Switching Server routes the call to the Media Server.

- The Media Server connects the incoming call (4) and, based on the number called (18665552637), launches the “Conferencing” application.
- The application prompts the user to enter the conference access code and validates it in the internal database (5).
- If a valid conference code is provided, the ID of the account that owns this conference room (conf1234) is retrieved. An authorization request is sent to PortaBilling (6) to check that usage of this particular conference number (18665552637) is allowed for this account and that the account has sufficient balance to cover the costs.
- If authorization is successful, the participant is allowed to join the conference.
- When the participant hangs up, an accounting request is sent to PortaBilling (7), so the account conf1234 (and the customer who owns it) are charged based on price per minute associated with this access number, and the call duration.

## Codec Licenses

Normally, a media server (such as the one used in PortaSIP®) will send pre-converted voice prompts to the user as a byte stream, so that no codec licenses are involved. In the case of conferencing server, however, the audio-stream with the voice of each participant has to be decoded in real time, and then sent back to each participant as an encoded audio-stream with the mixed sound. Thus, if commercial codecs (such as g729) are used, a codec license is required for each voice channel being used simultaneously. The conferencing server license does not include any codec licenses, and customers should procure such licenses independently.

## Video Conferencing

PortaSwitch® supports video conferencing so that during the video conference all participants can see the other participants in the conference.

This technology is useful for business customers because it offers them the opportunity to hold meetings, conferences, presentations and trainings remotely, without the need for all parties to be in one single location, thus saving time and money. Apart from the business sphere, this service can be useful in other life situations: for education, medicine, mass media, and of course, for personal use (e.g., communicating with distant relatives).

Video conferencing services provided by PortaSwitch® are manageable by the end user via the UM Self-care interface. Aside from the options available for audio conferences, the user can record a welcome video to be

displayed during the authentication or Music on Hold. Video conferencing users can open the OSD (on-screen display) menu by pressing the # key on the phone keypad. The OSD menu provides a list of conference participants and instructions for how to switch among them.

Video conferencing service supports video in CIF (352\*288) resolution and one of the most commonly used video codecs – H.264. PortaSIP serves as a multiplexer, so each participant can choose a specific video stream to watch and only that stream is sent to them - this optimizes bandwidth usage. Since entire video streams are switched / duplicated and no actual video content conversion is done - that translates to high performance (a single PortaSIP server can support up to 50 simultaneous video streams) with no additional costs for codec licenses.

## 2nd number service

Customers whose businesses receive many incoming calls may want to have one or more additional contact numbers for those purposes that are separate from their existing home or personal mobile numbers. At the same time, they may still want to be able to answer incoming calls to those numbers using their home or mobile phones. PortaBilling® now allows you to provide a so-called 2nd number service to satisfy those requirements.

Let's take a look at the following example:

- A customer with the mobile phone number 42073723123 buys a 2nd number service from you.
- You allocate another number for him, e.g. 42027777100, from the DID range and create an account in PortaBilling® that represents that phone number.
- Add the alias 42073723123@pstn (the “Allow authentication/registration” flag should be disabled for this) to the account 42027777100 to associate the customer's external phone number with the DID.
- Set the default answering mode to “Forward then voicemail” for this account.

### Listening to voice mail and making an outgoing call

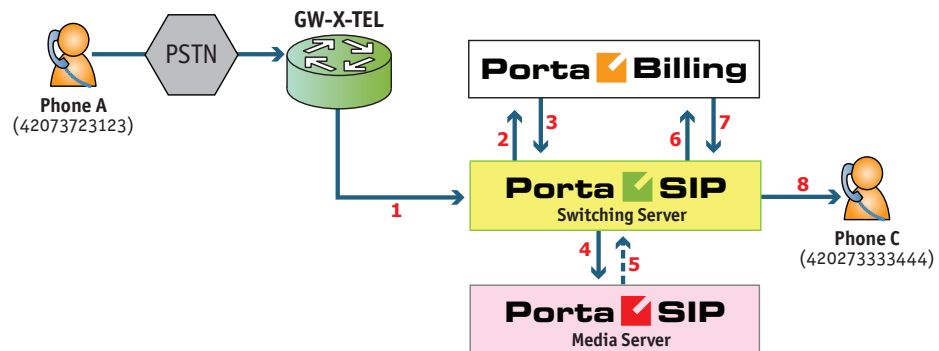

- From his 42073723123 mobile (1), the customer dials the phone number 42027777100 that was provided to him.
- The Switching Server sends an authorization request to billing (2).
- He is authorized by ANI 42073723123, and since 42073723123@pstn is an alias of the number dialed, the call is treated as an incoming call to the user's own mailbox.
- The authorization confirmation, including the routing list (with just the Media Server in it), is sent back to the Switching Server (3). The Switching Server routes the call to the Media Server.
- The Media Server connects the incoming call (4) and launches the "Voicemail Access" application.
- The customer can listen to messages the same way he would from his IP phone.
- If, after navigating the menu structure, the customer chooses the option of making an outgoing call, he will be prompted to input the destination.
- Customer inputs 420273333444.
- The Media Server sends an INVITE request to the Switching Server (5).
- The Switching Server sends an authorization request to billing (6).
- Billing sends an authorization response to the Switching Server (7).
- The Switching Server sends the call (8) to 420273333444 (the party being called will see 42027777100 as the CLI).

## Receiving an incoming call

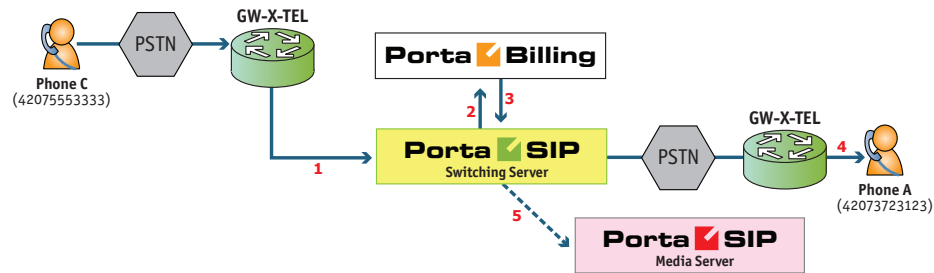

- From PSTN (42075553333), the user dials (1) customer's number: 42027777100.
- The Switching Server sends an authorization request to billing (2).
- The account for ANI authentication is not found and the call is treated as an incoming call to the 42027777100 account. PortaBilling® recognizes that this account has Follow-me services enabled, and produces a list of routes, accordingly.
- The authorization confirmation including the routing list (with the Follow-me number and the Media Server in it), is sent back to the Switching Server (3).

The Switching Server redirects the call (4) to a Follow-me number (customer will see 42027777100 as the CLI). If the call is not answered it will be redirected to voicemail (5), and the user can leave a message.

## Calling via Premium Number

Service providers can significantly increase their customer base by allowing subscribers of any other telco operator in the country to make cheap international calls via the service provider's network without any initial registration. Providers do not need to print and distribute calling cards or top-up vouchers; customers do not have to make a contract, perform online sign-up or purchase a card beforehand. This drastically simplifies the customer acquisition process and reduces associated costs.

A person can call a premium number that is registered on your network from his existing mobile phone or landline. For this call he will be charged by his operator according to the rate you assign to that particular premium number. In return, you can enable outgoing international calls to any of the destinations where your cost is lower than the revenue from the premium number. For instance, if you set the rate for premium number 9001234567 to \$0.10/min, you can allow calls made to any destination where you pay your vendors less than \$0.10/min to terminate the call. There is no need for the end-user to be provisioned in your system, you do not need to generate an invoice or request a payment: the telco, which

“owns” the end-user, will collect the funds from the end-user and then forward that amount (minus commission, if applicable) to you.

Usually there are several “tiers” of pricing – e.g. the price of calling landlines in most European countries is about the same, but the price of calling a mobile number in those countries is significantly higher, and some exotic destinations may even be more expensive. Multiple premium access numbers are utilized to address this, so for each group of countries / destination that fall within the same pricing tier, the end-user can be offered a premium number with a competitive price (while this price will still be higher than the average termination price in the group). For instance, the end-user can utilize a premium number with a \$0.20/minute price to call landlines in Europe, and another premium number with a \$0.50/minute price to call mobile networks in Europe. In the tariff for each premium number the administrator will put:

- Ordinary rates for destinations that customers can call (the price that the end-user pays to call a premium number is sufficient to cover the outgoing call there).
- Destinations that are too expensive to call using this premium number are listed in the tariff as “forbidden.” Nonetheless, price per minute information is still included in those rates and plays an important role. It suggests a per-minute rate for a premium number to call those destinations. This price will be used to search for the number that can be used to call those destinations from among all of the available premium numbers.

Let’s assume the average termination cost for destination 442 (UK-London) is \$0.12 and for 447 (UK Mobile) it’s \$0.22. There are two premium numbers, 12320 and 12350, with per minute rates of \$0.20 and \$0.50, respectively. Each of these numbers is configured in the Access Numbers section and the price per minute is set in the “Access Number Price” attribute. There are two separate tariffs, A and B – each linked to one of the numbers (see the examples in the **PortaSwitch® Unified Communications handbook** for detailed configuration examples). In tariff A, associated with the 12320 number, the service provider will enter the rate for 442 as normal, so users are allowed to make calls to UK-London via this number. The rate for 447 is marked as “forbidden” since otherwise, the service provider would lose money (the \$0.20 price per minute that the customer pays for the call to the 12320 number is less than the provider’s cost of \$0.22). So customers are “forbidden” from calling the 447 (UK-Mobile) destination with that premium number. In the “Price” attributes of the rate for 447 the administrator enters \$0.50, which means that the customer will be advised to use the premium number at the \$0.50 price per minute rate.

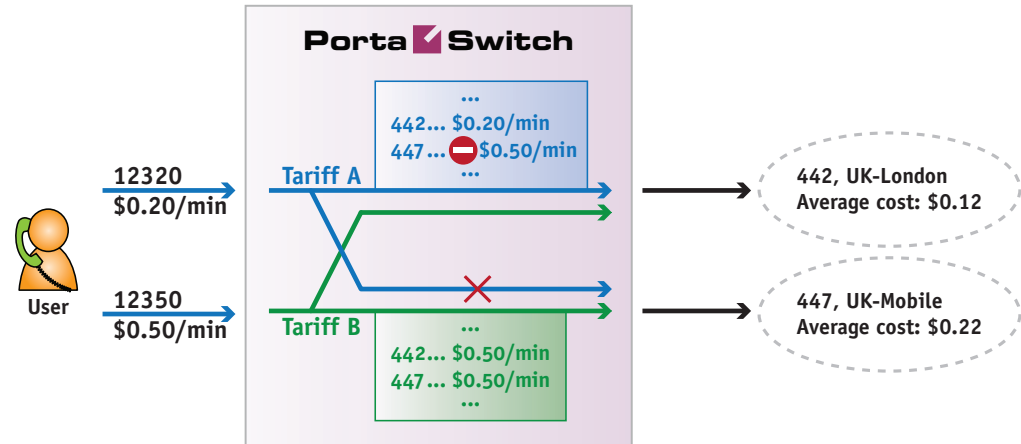

According to our example, that would be the 12350 number. The 12350 number has tariff B associated with it, and tariff B's rates are "normal" for both destinations, so either destination can be called by the customer using that 12350 premium number. This offers additional flexibility to the service provider since different destinations can be mapped using either the more or the less expensive premium numbers.

### Call Flow

- A user dials a premium number from his mobile phone or landline, the call arrives to the Media Server. The end-user is prompted to enter the destination number.
- The Media Server attempts to authorize a call to this number using PortaBilling®.
- If PortaBilling® confirms that calling that destination using this premium number is allowed, the Media Server will connect the outgoing call.
- If PortaBilling® rejects the request (the destination is marked as forbidden in the tariff), the Media Server will retrieve the price per minute entered in the forbidden rate – this is the "suggested" rate that we should collect for a call. Then the Media Server will search for a premium number IVR among the list of configured access numbers that has a "price per minute" attribute with the same value as the suggested price.
  - If an access number is found, the user will be informed that in order to complete the call he should use that premium number – the number and the rate for it are announced.
  - Otherwise the user is informed that a call to that destination is not possible and is advised to contact customer support for further assistance.

## Supported Services

### Leaving voice messages for a PortaSIP® user

The Media Server gives your SIP customers an automatic answering machine whenever they are not online or do not answer within a certain (configurable) time period. This service works when a call comes from PSTN, as well as when it comes from another SIP customer. See the [Call Scenarios](#) section above for detailed call flow descriptions.

### DISA functionality for One's own voice mailbox access application

When a customer accesses an IVR application to check his voicemail he may also want to make an outgoing call right away (e.g. to call back the person who left the voicemail). Now the customer can make an outgoing call from the voice mailbox by simply choosing that option from the application menu.

### Fax-to-email services

In addition to voice messages, UM-enabled SIP customers will be able to receive faxes on their “answering machine”. When a call is connected to the Media Server and the remote party initiates a fax transmission, the Media Server automatically detects this event and switches into fax receiving mode. The fax will be processed and then delivered to the user's mailbox as a .PDF or .TIFF document attached to an email message.

### Sending email messages to a PortaSIP® user

The Media Server also allows your SIP customers to have regular email accounts, where they can receive regular emails.

### Retrieving voice and email messages using a SIP phone

Your SIP customers will be able to retrieve their messages using a SIP phone. To do this, they must dial a special number, which transfers them to the Media Server IVR menu. This menu allows them to listen to recorded messages. Additionally, for SIP phones that support a message waiting indicator (MWI), the Media Server can automatically manage the SIP phone's MWI status, so that the user is notified when he has new messages.

### Retrieving voice messages, email messages and faxes using a web browser

Users can retrieve their messages and send regular email messages using a standard web browser. The advanced Java applet built into the interface



allows users not only to listen to voice messages, but also to compose new voice messages (a microphone is required). It is also possible to access the system using any email client that supports the IMAP or POP3 protocols.

### **Forwarding messages to an external email server**

When a new message arrives in the Media Server message storage, a full copy of the message, or just a short notification, can be sent to the user's other email address (e.g. corporate mail server or private gmail account), depending on the user's preferences.

### **Managing personal UM settings using a SIP phone**

In addition to retrieving messages, your SIP customers can manage their personal settings, such as greetings, from a SIP phone using the Media Server IVR menu.

### **Managing personal UM settings using a web browser**

Users are also able to manage their personal settings by logging into the UM self-care interface. The advanced Java applet built into the interface allows users to record personal greetings (a microphone is required).

### **Managing your current balance**

PortaSIP® users can listen to the current state of their accounts by using the IVR menu. Also, they can hear their current balance by dialing the access number for their mailbox and pressing option "0." There is also an IVR menu enabling the use of vouchers to add funds to an account. In *APPENDIX B. Balance Announcements*, there are balance announcement examples for different IVR configurations.

### **Prepaid card IVR**

The Media Server includes an IVR system that allows you to offer a prepaid card service for incoming VoIP calls. This IVR supports all the PortaBilling® extensions for the prepaid card application (access codes, real and announced call duration, and so on).

### **Auto attendant**

Every user can program his own set of menus for auto attendant, from a simple message such as "I am on vacation right now, press 1 to connect to my assistant" to a complex menu system with various options for small or medium-sized businesses. Users can program the voice dialog from their web browser, record voice prompts using a microphone on their PC or upload professionally recorded prompts, create multiple sub-menus and define an activity period for each of them, program their company's dial-by-name directory, construct multiple call queues, and so on.

## Voice-to-text Service

PortaSIP® is now integrated with the **GotVoice** service to provide “visual voicemails” to customers. Once a recorded voice message is delivered to the Media Server, it can be transferred to one of the GotVoice servers for processing. GotVoice uses state-of-the-art technology to recognize message contents, combining computerized speech recognition with live human assistance for those parts which cannot be processed automatically. In a matter of minutes the customer receives an email containing a transcript of the message text. This makes it possible to access the voicemail information via an email client or an SMS sent to a mobile phone.

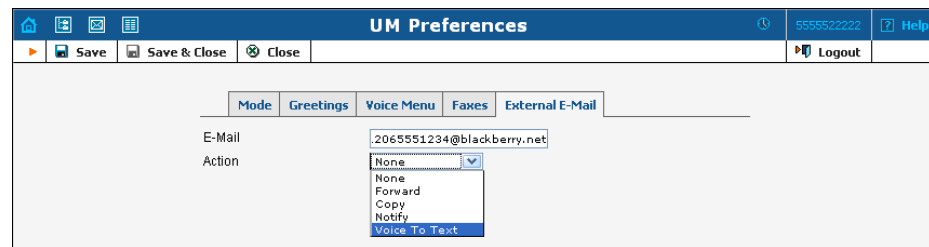

VoIP providers using PortaSwitch® can now reliably offer subscribers the ability to read their voicemail and process the information instantly. Using this service requires a contract with GotVoice (in order to be assigned an account giving access to the conversion API) and the basic PortaSwitch® configuration (to create rates for this service, etc.).

An ITSP must sign a contract with GotVoice for voice-to-text service and obtain the username/password information for accessing the conversion API. This information should be provisioned on the configuration server web interface.

Since voice-to-text is a paid service, where ITSP is charged for every conversion, charges should be applied to the customer, who is using the service. The Media Server performs authorization in PortaBilling® prior to conversion (to verify that the customer has sufficient funds). Once conversion has been completed, it sends a “charge” event to PortaBilling®.

## Registration for PINless Dialing Service via SMS

This is an extension to the “classic” PINless dialing service, in which the user is identified by his caller ID (ANI/CLI), maintains a balance in PortaSwitch® and is able to call any destination with charges applied to his balance. Traditionally, the registration for PINless dialing service is performed by the end-user via the purchase of a top-up card and then calling the special IVR. When the user’s balance is low, he needs to buy more top-up cards or pay his bill online. The registration via SMS (simply

send an SMS message to a certain number) is an easier alternative. A simplified registration process and further management of the account make this service especially convenient for users of mobile networks. The service provider has two options for collecting funds from the end-user:

- Send a request to the mobile operator that the end-user is connected to for a balance transfer. This option must be supported by the mobile carrier – its advantage is that any “ordinary” number can be used by the customer for sending an SMS.
- Establish a premium number where the end-user can send an SMS. Just like calls to premium numbers are charged differently than normal calls, messages to premium numbers are charged according to the higher rate (set by the service provider who owns the number). So for each message sent by the end-user, the mobile carrier will collect the money from the end-user and then pass it to you as the owner of the premium number.

To start using the service, the end-user simply sends an SMS with the message SUBSCRIBE to the registration number. Upon receiving the message, the SMS processing module in PortaSwitch® automatically provisions his account with the CLI/ANI of the mobile phone as the authentication ID; requests a balance transfer from the mobile operator and then adds these funds to the customer’s balance in PortaSwitch® so they can be used again in the future. End-user will receive an SMS that confirms the service activation and provides important service information, such as the number to call for PINless dialing or a username/password for accessing the web self-care. Once that occurs, the end-user can start using the service by dialing the access number and then entering the final destination number. The entire registration process is very easy to perform and can be completed in just a few seconds. PortaSwitch® can also perform an automated balance top-up: when the balance of the created account goes below a specified threshold, the system initiates another balance transfer from the user’s balance on the mobile network. The telecom client can disable this automatic recharge by sending an SMS to the SMS access number with the message STOP.

# 2. Appendices

## APPENDIX A. Configuration Parameters for IVR Applications

### Prepaid Card Calling

Field	Description
<b>ANI Authentication</b>	If <b>ANI Authentication</b> is turned on, the IVR application will attempt to authenticate the customer's phone number (ANI). If authentication is successful, the IVR does not ask for a PIN.
<b>ANI Translation Rule</b>	Caller identification (ANI or CLI number) is usually delivered in the "local" format, without the country code, etc., e.g. <b>021234567</b> . In this case, you need to translate the number into a unified format so it will match the ID of the billing account. The recommended format is a non-numeric prefix followed by an E164 number. In our earlier example, assuming that the country code is <b>44</b> , we applied ANI Translation Rule <b>s/^0/ani44/</b> to obtain " <b>ani4421234567</b> " as the authorization ID. This allows you to manage numbers from different countries (so they will not overlap) and the "ANI" prefix will ensure that these accounts are not confused with the actual phone numbers provisioned for on IP phones.
<b>Use ANI and Auth Code</b>	This feature enables service for enterprise customers when multiple individuals place outgoing calls using the same caller number (typically from the company's main phone line).  The IVR application finds the customer's phone number (ANI) and his Company ID (in this account's <b>associated number</b> field) and collects the user's Authentication Code. The call is then authorized and billed to the account with an ID consisting of a <i>Company ID</i> followed by the # sign and the <i>Authentication Code</i> , e.g. <b>534564#555</b> .
<b>Minimum Auth Code Length</b>	The minimum number of characters the authentication code consists of. By default: 4.
<b>Maximum Auth Code Length</b>	The maximum number of characters the authentication code consists of. By default: 4.
<b>Manual Authentication</b>	If <b>ANI authentication</b> is disabled or fails for some reason, users will still be able to authenticate their identities by using their PIN numbers when this option is enabled.

<b>PIN Translation Rule</b>	When the <b>Check Service Password</b> option is enabled and the <b>PIN Translation Rule</b> is set, the IVR application modifies the collected PIN according to the PIN translation rule that allows the use of an ANI-based account (for example, ani442031234567) for PIN authentication. This provides your end-users, normally identified by caller IDs (ANI/CLI), with the option of making calls from other phone numbers without having to input hard-to-remember PIN numbers.
<b>Auto Registration</b>	If the user's ANI is not found and PIN authentication is successful, the user will be prompted to register his ANI for future PINless dialing. If the user confirms, the ANI number he is calling from is added as an alias to his account. The next time a call is made from that phone number, it will be authenticated by the ANI and he will not be asked to enter a PIN number.
<b>Auto Registration Without Confirmation</b>	When this option is enabled, the IVR will not ask for confirmation before registering a user's ANI for future PINless dialing.
<b>Minimum Card Length</b>	Minimum length of a card number. By default: 11.
<b>Maximum Card Length</b>	Maximum length of a card number. By default: 11.
<b>Maximum Login Attempts</b>	Specify maximum number of attempts for user to enter a card number. By default: 3.
<b>Authorize with IVR Session ID</b>	PortaBilling® provides the same Routing Plan within a session. If you are using the Routing Plan function, you may need to disable this option in order to allow the Billing Engine to recover its separate routing plan for each authorization. Note: When disabled, the Media Server will generate a new h323-conf-id for every authorization request.
<b>Check Service Password</b>	Use this option to increase the security of PIN-less dialing service or simply to prevent unauthorized ANI usage when ANI Authentication is enabled. Upon collecting an ANI number, IVR prompts customer for their password and uses it for account validation (the password provided must match the account's Service Password). Note: If the account has an empty service password field, any user input matches it.
<b>Minimum Password Length</b>	Minimum number of characters the valid service password consists of. By default: 4.
<b>Maximum Password Length</b>	Maximum number of characters the valid service password consists of. By default: 4.

<b>Languages</b>	This enables you to select language(s) to be used as voice prompts. Click the wizard icon  to open the language selection window.
<b>Conf Language List is Preferred</b>	If this box is checked, the language list defined on this page has a higher preference than the account's preferred language.
<b>Prompts Brand</b>	IVR prompts can be customized per Access Number. Specify the directory where the custom prompt files are located. The Media Server will look for the prompts in that folder first and if found – use them. Otherwise, it will use the default files. (For example, put customized English prompts under the directory /porta_var/porta-am/prompts/brands/ my_company/en/ and specify “my_company” in this field).
<b>Play Welcome Message</b>	If enabled, the IVR will play the welcome message to the user once he reaches an access number.
<b>Restriction for Calling with Low Balance</b>	When account balance is less than product breakage and <b>disconnect</b> is defined, IVR plays the “you have insufficient funds” voice prompt and disconnects the call. If <b>no outgoing calls</b> is defined, IVR prompts for the destination number but gives a busy tone and drops the call immediately after dialing it. Option <b>none</b> disables this feature.
<b>Minimum Voucher Length</b>	Minimum length of a voucher number. By default: 11 characters.
<b>Maximum Voucher Length</b>	Maximum length of a voucher number. By default: 11 characters.
<b>Announce Balance</b>	If enabled, the IVR will announce the current balance for the user before prompting for the phone number he wishes to reach.

<p><b>Credit Accounts Balance Announcement</b></p>	<p>You can configure your IVR applications to announce the current balance <i>for credit accounts</i> in one of two modes:</p> <ul style="list-style-type: none"> <li>• Funds / balance – For prepaid customers (those who have a credit limit of 0 or less), announce “available funds” (calculated as credit limit minus balance) and announce the current balance for others (postpaid customers);</li> <li>• Balance – Always announce balance (this is the classic mode, ideal for typical postpaid customers).</li> </ul> <p>Note that a third “Backward compatibility” mode is enabled by default. It preserves the announcements exactly the way they worked in releases prior to MR35. In <i>APPENDIX B. Balance Announcements</i>, there are balance announcement examples for different IVR configurations.</p>
<p><b>Announce Credit Limit</b></p>	<p>If enabled, the balance announced to the end user will be followed by an announcement of the credit limit. This allows you to separate cases where credit limits are assigned only as a precaution (and so the end user should not really know about them) from cases where they are an integral part of the service (e.g. loyal customers are rewarded with an increased credit limit the longer they stay with you).</p>
<p><b>Enable Self-care menu</b></p>	<p>Enables the menu with additional options such as making a call using another prepaid card or the balance top-up. User can enter this menu by pressing the # key.</p>
<p><b>Play an announcement about Self-care menu</b></p>	<p>If enabled, the IVR will allow the user to enter the Self-care menu by pressing the # key.</p>
<p><b>Check Associated Number</b></p>	<p>When enabled, the prepaid card application checks if the account has specified an associated number. If it has, the call is redirected to this number.</p> <p>For example, the user buys a PSTN number (e.g. 1800123), a corresponding account is created in PortaBilling® and the user specifies his own mobile number as the associated number. In this case if anyone calls his PSTN number (e.g. 1800123), the call is automatically redirected to his mobile phone.</p>
<p><b>Announce Time</b></p>	<p>When a user inputs the destination, IVR announces the maximum call duration allowed for this destination and then connects the call.</p>



<b>Use special access code for first calls</b>	If enabled, a special tariff will be used for the first outgoing call made by users with prepaid cards. This tariff should be associated with the appropriate access code in the product's <b>Services and Rating</b> list. This access code depends on the <b>Use fixed access code for first calls</b> option described below.
<b>Use fixed access code for first calls</b>	This option specifies the special access code format that must be applied for the <i>first</i> outgoing call with prepaid cards. If this option is enabled, then the "FIRSTCALL" access code will be used. If this option is disabled, then the "FIRST#12345" access code will be used, where 12345 is the access number dialed.
<b>Use Announcement Tariff</b>	It is possible to use different tariffs for the announcement of the maximum call duration allowed and the rate for this call. The first (transparent) tariff should be associated with the "ANNOUNCE+DNIS" access code in the product's <b>Services and Rating</b> list. The second tariff should be associated with an actual access code. Thus, the user hears the time announced according to the first tariff, while the call is actually authorized and rated according to the second tariff.
<b>Select Outgoing Tariff Based on ANI</b>	If enabled, the calling card IVR can look up the "class" (defined as a destination group) for the caller's number and then use the class name as the "access code" when selecting a specific tariff in a product.
<b>Seconds Rounding Mode</b>	This option defines the way the seconds portion of "available time" is announced to a customer: <ul style="list-style-type: none"> <li>• <b>none</b> – there is no rounding, so the time is announced including seconds, e.g. "Five minutes and 49 seconds."</li> <li>• <b>up</b> – the time is rounded up to the nearest minute, so 5:49 will be announced as "Six minutes."</li> </ul>
<b>Play Pre-ring MOH</b>	By default, the calling party hears a ringtone while waiting until the remote party answers. You may want to replace the ringtone with music on hold (MOH). Check this option to allow IVR to play a special MOH ring when the call has already been placed but the ring signal has not yet been received.

<b>Dynamic Reauthorization</b>	<p>Enable this feature to perform dynamic reauthorization for calls made through this access number. Dynamic reauthorization is required in cases where an account is concurrently using multiple services and making a payment while the session is still in progress.</p> <p>Please consult the <i>Overdraft Protection</i> section in the <b>PortaBilling® Administrator Guide</b> for more information.</p>
<b>Music on Hold Class</b>	<p>Specify a Pre-ring MOH class here. Note: Ringtone files for custom MOH should be placed under /porta_var/porta-um/prompts/moh/OPTION_VALUE/ (e.g. for the MOH class “my-ringtone” the path will be /porta_var/porta-um/prompts/moh/my-ringtone/).</p>
<b>End Announce Time, sec</b>	<p>This feature announces the remaining time in seconds or simply plays a “beeping” sound. This “time left” warning is played when there are a specified number of seconds left before the call is disconnected.</p>
<b>End Announce Type</b>	<p>Choose one of the following types of “time left” warnings:</p> <ul style="list-style-type: none"> <li>• beep – plays “beeping” sound;</li> <li>• voice – announces the remaining time in seconds.</li> </ul>
<b>Disconnect Call Before, sec</b>	<p>The call can be disconnected before an account’s balance is actually depleted. Specify in seconds (till the calculated end of the call) when to disconnect the call.</p>
<b>Maximum Dial Attempts</b>	<p>Maximum number of dial attempts within one session. By default: 3.</p>
<b>Premium Number Subscribe Command</b>	<p>Specify the subscribe command, which must be sent in an SMS to the premium number in order to register the customer’s ANI.</p>
<b>Premium Number SMS Number</b>	<p>Specify the SMS number where the customer can send an SMS for registering his ANI.</p>
<b>Premium Number Deposited Amount</b>	<p>Specify the amount which will be transferred from the customer’s telecom balance to his account in your PortaBilling®.</p>
<b>Premium Number Currency</b>	<p>Specify the ISO 4217 currency code (e.g. USD) for recharging purposes.</p>

## Callback Calling

Field	Description
<b>Authenticate by</b>	<p>This option defines a user-name for an authentication request. Choose one of the following:</p> <ul style="list-style-type: none"> <li>• <b>ani</b> – Calling-Station-ID (caller’s number) is used for an authentication request.</li> <li>• <b>dnis</b> – Called-Station-ID (access number which was dialed) is used for an authentication request. This application establishes a callback to the associated number parameter of the account equal to the access number.</li> <li>• <b>none</b> – Do not immediately authenticate. This application prompts the user to enter a card number for authentication after calling the user back.</li> </ul>
<b>ANI Translation Rule</b>	<p>If ANI authentication is used, the voice application will attempt to authenticate the customer’s phone number (so he does not have to enter a PIN). Unfortunately, caller identification (the ANI or CLI number) is usually delivered in a specific format (e.g. “local” - without the country code and area code: <b>021234567</b>). In this case, you need to translate the number into a unified format so it matches the ID of the billing account. The recommended format is a non-numeric prefix followed by an E164 number - in our earlier example (assuming that the country code is <b>44</b>) we applied ANI Translation Rule <b>s/^0/cb44/</b> to obtain “<b>cb4421234567</b>” as the authorization ID. This allows you to manage numbers from different countries (so they do not overlap) and the “cb” prefix ensures that these accounts are not confused with actual phone numbers provisioned for on IP phones.</p>
<b>Send Authorization</b>	<p>When enabled, an authorization request will be sent along with authentication. It allows you to:</p> <ul style="list-style-type: none"> <li>• check if the caller has sufficient balance to initiate a call leg (i.e., user will not be called back if the balance is insufficient).</li> <li>• block some destinations for callback calls in the account’s tariff (mark destinations as forbidden in the appropriate tariff rates).</li> <li>• use a <b>Minimum Sufficient Time</b> option.</li> </ul>

<b>Minimum Sufficient Time</b>	Specify the minimum amount of seconds a user needs for leg A in order to use the callback service (applicable when <b>Send Authorization</b> is set to <b>Yes</b> and <b>Minimum Sufficient Time</b> > 0).
<b>Dial Translation Rule</b>	When the caller identification (ANI or CLI number) is delivered in a specific format (e.g. “local”) and should be modified for a callback, this translation rule is used.  For example, when caller identification is delivered in a domestic European dialing format (0 + area code + phone number, e.g. <b>0 5 888 7766</b> ) and we need to call the user back using an E164 format. In this case (assuming that the country code is <b>44</b> ) we would apply Dial Translation Rule <b>s/^0/44/</b> to obtain <b>44 5 888 7766</b> as the number to call back.
<b>Wait Time</b>	Delay (in seconds) before the callback application calls the user back.
<b>Auto Registration</b>	When enabled, it allows a caller to use callback with the auto registration feature. When the customer dials an access number, the system drops the call to initiate the callback. Customer is prompted to enter a voucher number and after validation, the system creates a new account with the exact same options/product as an etalon account (an etalon account is defined as a parameter for each separate access number).
<b>Etalon Account</b>	Specify the account ID here to use its configuration properties as an etalon for all auto registered accounts.
<b>Minimum Card Length</b>	Minimum length of a card number. By default: 11.
<b>Maximum Card Length</b>	Maximum length of a card number. By default: 11.
<b>Maximum Login Attempts</b>	Maximum number of attempts for a user to enter a card number. By default: 3.
<b>Use Fake Account</b>	During callback, the user is asked to enter his card number. In case of unsuccessful authorization (e.g. the user has not entered a valid number) a fake account will be used for charging leg A.  Enable the <b>Use Fake Account</b> option to use a fake account for a PIN-based callback scenario. By default: no.

<b>Fake Account</b>	Specifies a fake account. Also, you can allow/deny certain destinations in this account's tariff as the initial callback will be authorized with the 'fake account'. Note: If it is not defined, the Media Server uses the application access number by default.
<b>Languages</b>	This enables you to select language(s) to be used for voice prompts. Click the wizard icon  to open the language selection window.
<b>Conf Language List is Preferred</b>	If this box is checked, the language list defined on this page has a higher preference than the account's preferred language.
<b>Prompts Brand</b>	IVR prompts can be customized per Access Number. Specify the directory where custom prompt files are located. The Media Server will look for the prompts in that folder first and if found – use them. Otherwise, it will use default files. (For example, put customized English prompts under the directory /porta_var/porta-um/prompts/brands/my_company/en/ and specify “my_company” in this field).
<b>Play Welcome Message</b>	If enabled, the IVR will play the welcome message to the user once an access number is reached.
<b>Restriction for Calling with Low Balance</b>	When account balance is less than product breakage and <b>disconnect</b> is defined, IVR plays the “you have insufficient funds” voice prompt and disconnects the call. If <b>no outgoing calls</b> is defined, IVR prompts for the destination number but gives a busy tone and drops the call immediately after dialing it. Option <b>none</b> disables this feature.
<b>Announce Balance</b>	If enabled, the IVR will announce the current balance for the user before prompting for the phone number he wishes to reach.

<p><b>Credit Accounts Balance Announcement</b></p>	<p>You can configure your IVR applications to announce the current balance <i>for credit accounts</i> in one of two modes:</p> <ul style="list-style-type: none"> <li>• Funds / balance – For prepaid customers (those who have a credit limit of 0 or less), announce “available funds” (calculated as credit limit minus balance) and announce the current balance for others (postpaid customers);</li> <li>• Balance – Always announce balance (this is the classic mode, ideal for typical postpaid customers).</li> </ul> <p>Note that a third “Backward compatibility” mode is enabled by default. It preserves the announcements exactly the way they worked in releases prior to MR35. In <i>APPENDIX B. Balance Announcements</i>, there are balance announcement examples for different IVR configurations.</p>
<p><b>Announce Credit Limit</b></p>	<p>If enabled, the IVR will announce the credit limit as well as the account balance (applicable when <b>Credit Accounts Balance Announcement</b> is set to “balance” or “funds / balance”).</p>
<p><b>LegA CLD Prefix</b></p>	<p>Leg A (callback to a user’s number) access code prefix. Allows billing leg A with different tariff. A separate <b>Services and Rating</b> entry with the appropriate access code and tariff should exist in the product’s <b>Services and Rating</b> list.</p> <p>Note: Access code must contain DNIS after the Prefix. For example, if the <b>LegA CLD Prefix</b> is LEG_A and the Access Number is 12125551234, then the Access Code should be LEG_A12125551234.</p>
<p><b>LegB CLD Prefix</b></p>	<p>Leg B (user’s call to destination) access code prefix. Allows billing leg B with different tariff. A separate <b>Services and Rating</b> entry with the appropriate access code and tariff should exist in the product’s <b>Services and Rating</b> list.</p> <p>Note: Access code must contain DNIS after the Prefix. For example, if the <b>LegB CLD Prefix</b> is LEG_B and the Access Number is 12125551234, then the Access Code should be LEG_A12125551234.</p>

<b>Expected Connect Time</b>	This option verifies that the account's balance is sufficient for the leg B setup time. If the <b>Expected Connect Time</b> value is more than the maximum leg A duration, leg B will not be allowed. By default: 20 seconds.
<b>Special Charge if LegB Fails</b>	By enabling this, you can charge users differently for calls with failed leg B (e.g. incomplete call is not charged). Just add a new <b>Services and Rating</b> entry to the product's <b>Services and Rating</b> list, set its access code to "CALLBACK_FAIL" and associate it with a special tariff.
<b>Strict Authorization</b>	When enabled, call leg A will be disconnected if caller doesn't have sufficient funds to place call leg B.
<b>Announce Time</b>	When user inputs the destination, IVR announces the maximum call duration allowed to this destination and then connects the call.
<b>Use Announcement Tariff</b>	It is possible to use different tariffs for the announcement of the maximum call duration allowed and for rating this call. The first (transparent) tariff should be associated with the "ANNOUNCE+DNIS" access code in the product's <b>Services and Rating</b> list. The second tariff should be associated with an actual access code. Thus, the user hears the time announced according to the first tariff, while the call is actually authorized and rated according to the second tariff.
<b>Seconds Rounding Mode</b>	This option defines the way the seconds portion of "available time" is announced to a customer: <ul style="list-style-type: none"> <li>• <b>none</b> – there is no rounding, so the time is announced including seconds, e.g. "Five minutes and 49 seconds."</li> <li>• <b>up</b> – the time is rounded up to the nearest minute, so 5:49 will be announced as "Six minutes."</li> </ul>
<b>Play Pre-ring MOH</b>	By default, the calling party hears a ringtone while waiting until the remote party answers. You may want to replace this ringtone with music on hold (MOH). Check this option to allow IVR to play a special ringing MOH when the call has been placed but the ring signal has not yet been received.

<b>Music on Hold Class</b>	Specify a Pre-ring MOH class here. Note: Ringtone files for custom MOH should be placed under /porta_var/porta-um/prompts/moh/OPTION_VALUE/ (e.g. for the MOH class “my-ringtone” the path will be /porta_var/porta-um/prompts/moh/my-ringtone/).
<b>End Announce Time</b>	This feature announces the remaining time in seconds or simply plays a “beeping” sound. This “time left” warning is played when a specified number of seconds is left before the call is disconnected.
<b>End Announce Type</b>	Choose one of the following types of “time left” warnings: <ul style="list-style-type: none"> <li>• beep – play “beeping” sound;</li> <li>• voice – announce the remaining time in seconds.</li> </ul>
<b>Disconnect Call Before</b>	You can configure the system to disconnect a call before an account’s balance is actually depleted. Specify in seconds (till the calculated end of the call) when to disconnect the call.
<b>Maximum Dial Attempts</b>	Maximum number of dial attempts within one session. By default: 3.

## Account Top-up via Credit Card

Field	Description
<b>ANI Translation Rule</b>	Caller identification (ANI or CLI number) is usually delivered in the “local” format, without the country code, etc., e.g. <b>021234567</b> . In this case, you need to translate the number into a unified format so it will match the ID of the billing account. The recommended format is a non-numeric prefix followed by an E164 number. In our earlier example, assuming that the country code is <b>44</b> , we applied ANI Translation Rule <b>s/^0/ani44/</b> to obtain “ <b>ani4421234567</b> ” as the authorization ID. This allows you to manage numbers from different countries (so they will not overlap) and the “ANI” prefix will ensure that these accounts are not confused with the actual phone numbers provisioned for on IP phones.
<b>Use Account Information Provided by</b>	If enabled, an IVR application securely identifies a user if his account was originally authenticated by the PortaSIP® Switching Server instead of



<b>PortaSIP</b>	<p>attempting to authenticate the customer's phone number (ANI). Only enable this for access numbers dialed from SIP phones connected to PortaSwitch® (calls within your VoIP network).</p> <p>This feature is useful in cases when normal ANI authentication by the IVR application can either be very difficult or unsafe (as the calling account may be mismatched):</p> <ul style="list-style-type: none"> <li>○ The end user makes a call from his / her IP phone with a CLI that is either hidden or different from the authenticated account ID;</li> </ul> <p>The account ID is an internal ANI number (e.g. 000999123) or even a non-E164 identifier like an email address that can't be used as a normal CLI for outgoing calls.</p>
<b>Languages</b>	This enables you to select language(s) to be used for voice prompts. Click the wizard icon  to open the language selection window.
<b>Conf Language List is Preferred</b>	If the box is checked, the language list defined on this page has a higher preference than the account's preferred language.
<b>Prompts Brand</b>	IVR prompts can be customized per Access Number. Specify the directory where custom prompt files are located. The Media Server will look for the prompts in that folder first and if found – use them. Otherwise, it will use default files. (For example, put customized English prompts under the directory /porta_var/porta-um/prompts/brands/ my_company/en/ and specify “my_company” in this field).
<b>Minimum Card Length</b>	Minimum length of a card number. By default: 11.
<b>Maximum Card Length</b>	Maximum length of a card number. By default: 11.
<b>Maximum Login Attempts</b>	Specify maximum number of attempts for a user to enter a card number. By default: 3.
<b>Minimum Voucher Length</b>	Minimum length of a voucher number. By default: 11.
<b>Maximum Voucher Length</b>	Maximum length of a voucher number. By default: 11.
<b>Minimum Sum</b>	Specify minimum amount of funds to be transferred from a customer's credit card.
<b>Credit Accounts Balance</b>	You can configure your IVR applications to announce the current balance <i>for credit accounts</i> in

<b>Announcement</b>	<p>one of two modes:</p> <ul style="list-style-type: none"> <li>• Funds / balance – For prepaid customers (those who have a credit limit of 0 or less), announce “available funds” (calculated as credit limit minus balance) and announce the current balance for others (postpaid customers);</li> <li>• Balance – Always announce balance (this is the classic mode, ideal for typical postpaid customers).</li> </ul> <p>Note that a third “Backward compatibility” mode is enabled by default. It preserves the announcements exactly the way they worked in releases prior to MR35. In <i>APPENDIX B. Balance Announcements</i>, there are balance announcement examples for different IVR configurations.</p>
<b>Announce Credit Limit</b>	<p>If enabled, the IVR will announce the credit limit as well as the account balance (applicable when <b>Credit Accounts Balance Announcement</b> is set to “balance” or “funds / balance”).</p>
<b>Customer Center Number</b>	<p>Specify the number where a user may reach an operator.</p>

## Account Top-up via Voucher

<b>Field</b>	<b>Description</b>
<b>ANI Translation Rule</b>	<p>Caller identification (ANI or CLI number) is usually delivered in the “local” format, without the country code, etc., e.g. <b>021234567</b>. In this case, you need to translate the number into a unified format so it will match the ID of the billing account. The recommended format is a non-numeric prefix followed by an E164 number. In our earlier example, assuming that the country code is <b>44</b>, we applied ANI Translation Rule <b>s/^0/ani44/</b> to obtain “<b>ani4421234567</b>” as the authorization ID. This allows you to manage numbers from different countries (so they will not overlap) and the “ANI” prefix will ensure that these accounts are not confused with the actual phone numbers provisioned for on IP phones.</p>

<p><b>Use Account Information Provided by PortaSIP</b></p>	<p>If enabled, an IVR application securely identifies a user if his account was originally authenticated by the PortaSIP® Switching Server instead of attempting to authenticate the customer’s phone number (ANI). Only enable this for access numbers dialed from SIP phones connected to PortaSwitch® (calls within your VoIP network).</p> <p>This feature is useful in cases when normal ANI authentication by the IVR application can either be very difficult or unsafe (as the calling account may be mismatched):</p> <ul style="list-style-type: none"> <li>○ The end user makes a call from his / her IP phone with a CLI that is either hidden or different from the authenticated account ID;</li> </ul> <p>The account ID is an internal ANI number (e.g. 000999123) or even a non-E164 identifier like an email address that can’t be used as a normal CLI for outgoing calls.</p>
<p><b>Prompts Brand</b></p>	<p>IVR prompts can be customized per Access Number. Specify the directory where custom prompt files are located. The Media Server will look for the prompts in that folder first and if found – use them. Otherwise, it will use default files. (For example, put customized English prompts under the directory /porta_var/porta-um/prompts/brands/ my_company/en/ and specify “my_company” in this field).</p>
<p><b>Maximum Login Attempts</b></p>	<p>Specify maximum number of attempts for a user to enter a card number. By default: 3.</p>
<p><b>Minimum Voucher Length</b></p>	<p>Minimum length of a voucher number. By default: 11.</p>
<p><b>Maximum Voucher Length</b></p>	<p>Maximum length of a voucher number. By default: 11.</p>
<p><b>Allow to transfer the balance from debit accounts</b></p>	<p>Select this checkbox to allow a customer to top-up his main account using another pre-paid card (i.e., from a debit account) in PortaBilling® instead of a top-up voucher.</p> <p>In order for the balance transfer between two accounts to function properly, the “donor” account must have the same currency and product as the “recipient” account and must never be used for making calls prior to the recharge (this is to prevent potential fraudulent attempts at “stealing” someone else’s balance).</p>

<p><b>Credit Accounts Balance Announcement</b></p>	<p>You can configure your IVR applications to announce the current balance <i>for credit accounts</i> in one of two modes:</p> <ul style="list-style-type: none"> <li>• Funds / balance – For prepaid customers (those who have a credit limit of 0 or less), announce “available funds” (calculated as credit limit minus balance) and announce the current balance for others (postpaid customers);</li> <li>• Balance – Always announce balance (this is the classic mode, ideal for typical postpaid customers).</li> </ul> <p>Note that a third “Backward compatibility” mode is enabled by default. It preserves the announcements exactly the way they worked in releases prior to MR35. In <i>APPENDIX B. Balance Announcements</i>, there are balance announcement examples for different IVR configurations.</p>
<p><b>Announce Credit Limit</b></p>	<p>If enabled, the IVR will announce the credit limit as well as the account balance (applicable when <b>Credit Accounts Balance Announcement</b> is set to “balance” or “funds / balance”).</p>

## One-stage Calling

Note that the number for this application must be in the format <special-prefix>%, e.g. 5061999%.

The process of One-stage calling to an Access Number is the following:

- The customer dials any number (e.g. 12065551234) from his home phone;
- The local telco sends this call to your system with a special 5061999 prefix (so, for example, the CLD is 506199912065551234); alternatively this special prefix can be added in the **Translation Rule** field of the particular connection or even dialed by the customer (this depends upon the agreement between the local telco and your company);
- The call is routed to the Media Server;
- The Media Server starts the One-stage calling application;
- The application strips the 5061999 prefix from the CLD and sends an authorization request to PortaBilling;
- PortaBilling® performs the authentication by ANI, checks whether the customer is allowed to call this particular destination

and the length of the maximum allowed call duration, and sends back a reply;

- IVR announces the maximum allowed call duration (if enabled);
- The application sends the call to the Switching Server (the CLD is 12065551234); and
- The Switching Server routes the call according to the system routing plan.

Field	Description
<b>ANI Translation Rule</b>	If ANI authentication is turned on, the voice application will attempt to authenticate the customer's phone number (so he does not have to enter a PIN). Unfortunately, caller identification (ANI or CLI number) is usually given in the “local” format, without a country code, etc.: <b>021234567</b> . In this case, you need to translate the number into a unified format so it matches the ID of an account for billing. The recommended format is a non-numeric prefix followed by an E164 number in our earlier example (assuming that the country code is <b>44</b> ) we applied ANI Translation Rule <b>s/^0/ani44/</b> to obtain “ <b>ani4421234567</b> ” as the authorization ID. This allows you to manage numbers from different countries (so they do not overlap) and the “ANI” prefix ensures that these accounts are not confused with actual phone numbers provisioned for on IP phones.
<b>Languages</b>	This enables you to select language(s) to be used for voice prompts. Click the wizard icon  to open the language selection window.
<b>Conf Language List is Preferred</b>	If the box is checked, the language list defined on this page has a higher preference than the account's preferred language.
<b>Prompts Brand</b>	IVR prompts can be customized per Access Number. Specify the directory where the custom prompt files are located. The Media Server will look for the prompts in that folder first and if found – use them. Otherwise, it will use default files. (For example, put customized English prompts under the directory <code>/porta_var/porta-um/prompts/brands/my_company/en/</code> and specify “my_company” in this field).
<b>Play Welcome Message</b>	If enabled, the IVR will play the welcome message to a user once he reaches an access number.

<b>Announce Time</b>	When user inputs the destination, IVR announces the maximum call duration allowed to this destination and then connects the call.
<b>Use Announcement Tariff</b>	It is possible to use different tariffs for the announcements of maximum call duration allowed and the call's rating. The first (transparent) tariff should be associated with the "ANNOUNCE+DNIS" access code in the product's <b>Services and Rating</b> list. The second tariff should be associated with an actual access code. Thus, the user hears the time announced according to the first tariff while the call is actually authorized and rated according to the second tariff.
<b>Seconds Rounding Mode</b>	This option defines the way the seconds portion of "available time" is announced to a customer: <ul style="list-style-type: none"> <li>• <b>none</b> – there is no rounding, so the time is announced including seconds, e.g. "Five minutes and 49 seconds."</li> <li>• <b>up</b> – the time is rounded up to the nearest minute, so 5:49 will be announced as "Six minutes."</li> </ul>

## One's Own Voice Mailbox Access

Field	Description
<b>Languages</b>	This enables you to select language(s) to be used for voice prompts. Click the wizard icon  to open the language selection window.

You can allow customers to make outgoing calls from their mailboxes. This can be enabled on the **Voice Applications Settings** tab.

## Premium Numbers

Field	Description
<b>Prompts Brand</b>	IVR prompts can be customized per Access Number. Specify the directory where the custom prompt files are located. The Media Server will look for the prompts in that folder first and if found – use them. Otherwise, it will use default files. (For example, put customized English prompts under the directory /porta_var/porta-um/prompts/brands/ my_company/en/ and specify "my_company" in this field).

<b>Special Username</b>	Specifies the ID of a specially configured premium number account. The account must have no credit limit (to allow unlimited chargeable calls); account's product must list all access numbers in its services and rating list and each one must be associated with a corresponding tariff.
<b>Customer Care Number</b>	Specifies the number a user can call if he experiences any difficulties using the service. This number will be announced to the user by the IVR.
<b>Access Number Price</b>	Specifies the price for this particular access number. If the user tries to dial a destination that is not covered by the access number he has called, PortaBilling® will try to find the proper access number by matching the price for the desired destination (in the tariff assigned to the current access number) with the value specified here. The user is then informed of it.

## Account Self-Care

Field	Description
<b>Languages</b>	This enables you to select language(s) to be used for voice prompts. Click the wizard icon  to open the language selection window.
<b>Prompts Brand</b>	IVR prompts can be customized per Access Number. Specify the directory where the custom prompt files are located. The Media Server will look for the prompts in that folder first and if found – use them. Otherwise, it will use default files. (For example, put customized English prompts under the directory /porta_var/porta-um/prompts/brands/ my_company/en/ and specify “my_company” in this field).
<b>Follow Me Timeout</b>	This specifies how long the IP phone will ring before the call goes to follow-me numbers.
<b>Play Welcome Message</b>	If enabled, the IVR will play the welcome message to the user once he reaches an access number.

## Balance information

Field	Description
<b>Use Early Media</b>	If enabled, the IVR will announce the account's balance without establishing a call so the end user is not charged by their telco.

<p><b>ANI Translation Rule</b></p>	<p>If ANI authentication is turned on, the voice application will attempt to authenticate the customer's phone number (so he does not have to enter a PIN). Unfortunately, caller identification (ANI or CLI number) is usually given in the “local” format, without a country code, etc.: <b>021234567</b>. In this case, you need to translate the number into a unified format so it matches the ID of an account for billing. The recommended format is a non-numeric prefix followed by an E164 number in our earlier example (assuming that the country code is <b>44</b>) we applied ANI Translation Rule <b>s/^0/ani44/</b> to obtain “<b>ani4421234567</b>” as the authorization ID. This allows you to manage numbers from different countries (so they do not overlap) and the “ANI” prefix ensures that these accounts are not confused with actual phone numbers provisioned for on IP phones.</p>
<p><b>Use Account Information Provided by PortaSIP</b></p>	<p>If enabled, an IVR application securely identifies a user if his account was originally authenticated by the PortaSIP® Switching Server instead of attempting to authenticate the customer’s phone number (ANI). Only enable this for access numbers dialed from SIP phones connected to PortaSwitch® (calls within your VoIP network).</p> <p>This feature is useful in cases when normal ANI authentication by the IVR application can either be very difficult or unsafe (as the calling account may be mismatched):</p> <ul style="list-style-type: none"> <li>○ The end user makes a call from his / her IP phone with a CLI that is either hidden or different from the authenticated account ID;</li> <li>○ The account ID is an internal ANI number (e.g. 000999123) or even a non-E164 identifier like an email address that can’t be used as a normal CLI for outgoing calls.</li> </ul>



<b>Prompts Brand</b>	IVR prompts can be customized per Access Number. Specify the directory where the custom prompt files are located. The Media Server will look for the prompts in that folder first and if found – use them. Otherwise, it will use default files. (For example, put customized English prompts under the directory /porta_var/porta-um/prompts/brands/ my_company/en/ and specify “my_company” in this field).
----------------------	---

## Call forwarding management

Field	Description
<b>Prompts Brand</b>	IVR prompts can be customized per Access Number. Specify the directory where the custom prompt files are located. The Media Server will look for the prompts in that folder first and if found – use them. Otherwise, it will use default files. (For example, put customized English prompts under the directory /porta_var/porta-um/prompts/brands/ my_company/en/ and specify “my_company” in this field).

## Conferencing

Field	Description
<b>Maximum Login Attempts</b>	Specify maximum number of attempts for a user to enter a card number. By default: 3.
<b>Prompts Brand</b>	IVR prompts can be customized per Access Number. Specify the directory where the custom prompt files are located. The Media Server will look for the prompts in that folder first and if found – use them. Otherwise, it will use default files. (For example, put customized English prompts under the directory /porta_var/porta-um/prompts/brands/ my_company/en/ and specify “my_company” in this field).
<b>Record with Review</b>	If enabled, the IVR will play back the name that the end user recorded; if preferred, it can be re-recorded.
<b>Play Welcome Message</b>	If enabled, the IVR will play the welcome message to the user once he reaches an access number.

## Holiday line management

Field	Description
<b>ANI Translation Rule</b>	If ANI authentication is turned on, the voice application will attempt to authenticate the customer's phone number (so he does not have to enter a PIN). Unfortunately, caller identification (ANI or CLI number) is usually given in the “local” format, without a country code, etc.: <b>021234567</b> . In this case, you need to translate the number into a unified format so it matches the ID of an account for billing. The recommended format is a non-numeric prefix followed by an E164 number in our earlier example (assuming that the country code is <b>44</b> ) we applied ANI Translation Rule <b>s/^0/ani44/</b> to obtain “ <b>ani4421234567</b> ” as the authorization ID. This allows you to manage numbers from different countries (so they do not overlap) and the “ANI” prefix ensures that these accounts are not confused with actual phone numbers provisioned for on IP phones.
<b>ANI Authentication</b>	If <b>ANI Authentication</b> is turned on, the IVR application will attempt to authenticate the customer's phone number (ANI). If authentication is successful, the IVR does not ask for a PIN.
<b>Minimum Card Length</b>	Minimum length of a card number. By default: 11.
<b>Maximum Card Length</b>	Maximum length of a card number. By default: 11.
<b>Maximum Login Attempts</b>	Specify maximum number of attempts for a user to enter a card number. By default: 3.
<b>Prompts Brand</b>	IVR prompts can be customized per Access Number. Specify the directory where the custom prompt files are located. The Media Server will look for the prompts in that folder first and if found – use them. Otherwise, it will use default files. (For example, put customized English prompts under the directory <code>/porta_var/porta-um/prompts/brands/ my_company/en/</code> and specify “my_company” in this field).

## Pass-through IVR

This IVR application introduces prepaid card calling features to traditional residential VoIP service. For example, the application can play a “time left” warning when a specified number of seconds is left – before the call

is disconnected. It can also announce the maximum call duration allowed to the dialed destination and then connect the call. In addition, the Pass-through IVR permits additional verification of the outgoing toll (e.g. on international) calls.

The administrator controls whether the outgoing calls are made in a normal fashion or if the calls are handled by the Pass-through IVR application. This is specified in the account's **Service Features** configuration section.

Please consult the *Voiceover Announcements* section in the **PortaSIP® Switching Server Administrator Guide** for more information.

Field	Description
<b>Maximum Length of the Auth Code</b>	Maximum allowable length for an authorization code. By default: 4.
<b>Maximum Login Attempts</b>	Specify maximum number of attempts for a user to enter a card number. By default: 3.
<b>Announce Time</b>	When user inputs the destination, the IVR announces the maximum call duration allowed to this destination and then connects the call. By default this feature is disabled.
<b>End Announce Type</b>	Choose one of the following types of “time left” warnings: <ul style="list-style-type: none"> <li>• beep – play “beeping” sound;</li> <li>• voice – announce the remaining time in seconds.</li> </ul>
<b>End Announce Time</b>	This feature announces the remaining time in seconds or simply plays a “beeping” sound. This “time left” warning is played when a specified number of seconds is left before the call is disconnected.
<b>Authorize Non-Free Calls</b>	Enable this option to perform an additional verification for toll calls. This will prevent unauthorized usage of phones available in public areas. Furthermore, if a single phone is shared among multiple users, then the outgoing calls can be billed to separate accounts; this will allow for accountability for each user based on the input authorization code. By default: disabled.  Note that if this option is disabled and the <b>Treat Auth Code as Part of Account ID</b> option is enabled at the same time, the user will only be able to make toll-free calls.

<b>Use Associated Number to Produce Auth ID</b>	When this option is enabled, the application checks for an associated number specified for the account. If there is one, the authorization is done using the associated number and authorization code input by the user (i.e. account's associated number followed by # followed by authorization code, e.g. 74951234567#1234) will be used to authenticate the call). By default this is disabled.
<b>Treat Auth Code as Part of Account ID</b>	<p>Enable this feature if a single phone is shared among multiple users and there is a need to bill outgoing calls to separate accounts; the account with ID <i>AccountID#AuthCode</i> (account ID followed by # followed by authorization code, e.g. 12121234567#1234) will be used to authenticate the call.</p> <p>If this feature is disabled, the input authorization code will be compared with the account's <b>Service Unblock Code</b> (defined in the <b>Fraud Detection</b> tab) to confirm that a legitimate user is attempting to make a call. By default this feature is enabled.</p>

## Payment remittance – TransferTo

Field	Description
<b>Minimum Card Length</b>	Minimum length of a card number. By default: 11.
<b>Maximum Card Length</b>	Maximum length of a card number. By default: 11.
<b>Maximum Login Attempts</b>	Specify maximum number of attempts for a user to enter a card number. By default: 3.
<b>Play Welcome Message</b>	If enabled, the IVR will play the welcome message to the user once he reaches an access number.
<b>Prompts Brand</b>	IVR prompts can be customized per Access Number. Specify the directory where the custom prompt files are located. The Media Server will look for the prompts in that folder first and if found – use them. Otherwise, it will use default files. (For example, put customized English prompts under the directory /porta_var/porta-um/prompts/brands/my_company/en/ and specify “my_company” in this field).

## Simplified account self-care

Field	Description
<b>Play Announcements</b>	If enabled, the IVR will play the announcements without establishing a call so the end user will not be charged by their telco.
<b>Use Account Information Provided by PortaSIP</b>	<p>If enabled, an IVR application securely identifies a user if his account was originally authenticated by the PortaSIP® Switching Server instead of attempting to authenticate the customer's phone number (ANI). Only enable this for access numbers dialed from SIP phones connected to PortaSwitch® (calls within your VoIP network).</p> <p>This feature is useful in cases when normal ANI authentication by the IVR application can either be very difficult or unsafe (as the calling account may be mismatched):</p> <ul style="list-style-type: none"> <li>○ The end user makes a call from his / her IP phone with a CLI that is either hidden or different from the authenticated account ID;</li> </ul> <p>The account ID is an internal ANI number (e.g. 000999123) or even a non-E164 identifier like an email address that can't be used as a normal CLI for outgoing calls.</p>
<b>ANI Translation Rule</b>	If ANI authentication is turned on, the voice application will attempt to authenticate the customer's phone number (so he does not have to enter a PIN). Unfortunately, caller identification (ANI or CLI number) is usually given in the "local" format, without a country code, etc.: <b>021234567</b> . In this case, you need to translate the number into a unified format so it matches the ID of an account for billing. The recommended format is a non-numeric prefix followed by an E164 number in our earlier example (assuming that the country code is <b>44</b> ) we applied ANI Translation Rule <b>s/^0/ani44/</b> to obtain " <b>ani4421234567</b> " as the authorization ID. This allows you to manage numbers from different countries (so they do not overlap) and the "ANI" prefix ensures that these accounts are not confused with actual phone numbers provisioned for on IP phones.

<b>Etalon Account</b>	Specify the account ID here to use its configuration properties as an etalon for all accounts.
<b>Prompts Brand</b>	IVR prompts can be customized per Access Number. Specify the directory where the custom prompt files are located. The Media Server will look for the prompts in that folder first and if found – use them. Otherwise, it will use default files. (For example, put customized English prompts under the directory /porta_var/porta-um/prompts/brands/my_company/en/ and specify “my_company” in this field).

## APPENDIX B. Balance Announcements

In the table below you can see available variants for balance announcements with the **Credit Accounts Balance Announcement** option set to **backward compatibility** or **funds / balance** value:

	<b>Backward Compatibility</b>	<b>Funds/Balance</b>
<b>Balance = 10; Credit Limit = 300</b>	“You have 290 dollars.”	“You have 290 dollars available.”
<b>Balance = 10; Credit Limit = n/a</b>	“You have unlimited available funds.”	“Your balance is 10 dollars.”
<b>Balance = -10; Credit Limit = 300</b>	“You have 310 dollars.”	“Your balance is minus 10 dollars.”
<b>Balance = -10; Credit Limit = 0</b>	“You have 10 dollars.”	“You have 10 dollars available.”

In the following table you can see available variants for balance announcements with the **Credit Account Balance Announcement** option set to **balance** value (with the **Announce Credit Limit** option enabled / disabled):

	<b>Balance</b>	
	<b>Without Credit Limit Announcement</b>	<b>With Credit Limit Announcement</b>
<b>Balance = 10; Credit Limit = 300</b>	“Your balance is 10 dollars.”	“Your balance is 10 dollars, your credit limit is 300 dollars.”
<b>Balance = 10;</b>	“Your balance is 10	“Your balance is 10

<b>Credit Limit = n/a</b>	dollars.”	dollars, there is no credit limit.”
<b>Balance = -10; Credit Limit = 300</b>	“Your balance is minus 10 dollars.”	“Your balance is minus 10 dollars, you credit limit is 300 dollars.”
<b>Balance = -10; Credit Limit = 0</b>	“Your balance is minus 10 dollars.”	“Your balance is minus 10 dollars, you credit limit is 0 dollars.”

## APPENDIX C. Supported DTMF Methods

PortaSIP® supports the following DTMF methods:

- Inband
- RFC 2833
- SIP INFO

## APPENDIX D. Fax Transmission-Supported Codecs

PortaSIP® supports high-quality fax transmission in the following codecs:

- T.38
- G711 (G711a and G711u)

## APPENDIX E. Supported Languages

The following tables show which languages are supported by specific Media Server IVR applications.

### Self-care IVR Applications

LANGUAGE \ APPLICATION	English (en)	Spanish (es)	French (fr)	Swiss French (fr-CH)	Hebrew (he)	Brazilian Portuguese (pt-BR)	Russian (ru)	Cantonese Chinese (yu)	Mandarin Chinese (cm)	Greek (el)	Arabic (ar)	Swedish (sv)	German (de)	Italian (it)	Myanmar (my)
Account top-up via credit card	Yes	Yes	No	No	No	No	No	No	Yes	No	Yes	Yes	Yes	Yes	No
Simplified account self-care	Yes	Yes	No	No	No	No	No	No	Yes	No	Yes	Yes	Yes	Yes	No
Call Forwarding management	Yes	Yes	Yes	No	Yes	No	Yes	No	Yes	No	Yes	Yes	Yes	Yes	No
Account Self-care	Yes	Yes	Yes	No	Yes	No	No	No	Yes	No	Yes	Yes	Yes	Yes	No
Account top-up via voucher	Yes	Yes	Yes	Yes	Yes	Yes	Yes	No	Yes	No	Yes	Yes	Yes	Yes	Yes
Balance information	Yes	Yes	Yes	No	No	No	Yes	No	Yes	No	Yes	Yes	Yes	Yes	Yes
One's own voice mailbox access (with PIN protection)	Yes	Yes	P	No	P	No	P	No	Yes	No	Yes	Yes	Yes	Yes	No
One's own voice mailbox access	Yes	Yes	P	No	P	No	P	No	Yes	No	Yes	Yes	Yes	Yes	No
Payment Remittance	Yes	Yes	No	No	No	No	No	No	No	No	No	No	Yes	Yes	No



<b>LANGUAGE</b>	<b>English (en)</b>	<b>Spanish (es)</b>	<b>French (fr)</b>	<b>Swiss French (fr-CH)</b>	<b>Hebrew (he)</b>	<b>Brazilian Portuguese (pt-BR)</b>	<b>Russian (ru)</b>	<b>Cantonese Chinese (yu)</b>	<b>Mandarin Chinese (cm)</b>	<b>Greek (el)</b>	<b>Arabic (ar)</b>	<b>Swedish (sv)</b>	<b>German (de)</b>	<b>Italian (it)</b>
<b>APPLICATION</b>														
<b>Account top-up via credit card</b>	Yes	Yes	No	No	No	No	No	No	Yes	No	Yes	Yes	Yes	Yes
<b>Simplified account self-care</b>	Yes	Yes	No	No	No	No	No	No	Yes	No	Yes	Yes	Yes	Yes
<b>Call Forwarding management</b>	Yes	Yes	Yes	No	Yes	No	Yes	No	Yes	No	Yes	Yes	Yes	Yes
<b>Account Self-care</b>	Yes	Yes	Yes	No	Yes	No	No	No	Yes	No	Yes	Yes	Yes	Yes
<b>Account top-up via voucher</b>	Yes	Yes	Yes	Yes	Yes	Yes	Yes	No	Yes	No	Yes	Yes	Yes	Yes
<b>Balance information</b>	Yes	Yes	Yes	No	No	No	Yes	No	Yes	No	Yes	Yes	Yes	Yes
<b>One's own voice mailbox access (with PIN protection)</b>	Yes	Yes	P	No	P	No	P	No	Yes	No	Yes	Yes	Yes	Yes
<b>One's own voice mailbox access</b>	Yes	Yes	P	No	P	No	P	No	Yes	No	Yes	Yes	Yes	Yes
<b>Payment Remittance</b>	Yes	Yes	No	No	No	No	No	No	No	No	No	No	Yes	Yes

## Outgoing Calling Applications

LANGUAGE \ APPLICATION	English (en)	Spanish (es)	French (fr)	Swiss French (fr-CH)	Hebrew (he)	Brazilian Portuguese (pt-BR)	Russian (ru)	Cantonese Chinese (yu)	Mandarin Chinese (cm)	Greek (el)	Arabic (ar)	Swedish (sv)	German (de)	Italian (it)	Myanmar (my)
<b>One-stage calling</b>	Yes	Yes	Yes	Yes	Yes	Yes	Yes	P	Yes	Yes	Yes	Yes	Yes	Yes	Yes
<b>Callback calling</b>	Yes	Yes	Yes	Yes	Yes	Yes	Yes	P	Yes	P	Yes	Yes	Yes	Yes	Yes
<b>Prepaid Card Calling</b>	Yes	Yes	Yes	P	P	Yes	Yes	P	Yes	P	Yes	Yes	Yes	Yes	P
<b>Premium Numbers</b>	Yes	Yes	No	No	No	No	No	No	No	No	No	No	Yes	No	No

## Other IVR Applications

LANGUAGE \ APPLICATION	English (en)	Spanish (es)	French (fr)	Swiss French (fr-CH)	Hebrew (he)	Brazilian Portuguese (pt-BR)	Russian (ru)	Cantonese Chinese (yu)	Mandarin Chinese (cm)	Greek (el)	Arabic (ar)	Swedish (sv)	German (de)	Italian (it)	Myanmar (my)
<b>Holiday line management</b>	Yes	Yes	Yes	No	No	No	No	No	Yes	No	Yes	Yes	Yes	Yes	No
<b>Conferencing</b>	Yes	No	No	No	No	No	No	No	No	No	No	No	No	No	No

- No – not supported
- Yes – fully supported
- P – partially supported (incomplete prompts list or prompts are out of date)

If account's currency is not supported by the IVR application, then IVR uses a default currency:

LANGUAGE	Supported currency (ISO 4217 code)	Default currency (ISO 4217 code)
Arabic	BHD, USD, EUR	BHD
Cantonese Chinese	USD, CNY	USD
English	USD, RUB, EUR, GBP, THB, INR, MYR, BND, AED, IRR, ZAR, CHF, CNY, DKK, MXN, TRY, NGN, BHD, AUD, HKD, NZD, SGD, PKR, JOD, IQD, EGP, PHP, IDR, BDT, CRC	USD
French	USD, EUR, RUB, GBP, THB, INR, MYR, BND, AED	USD
German	USD, RUB, EUR, GBP, CHF	EUR
Greek	USD, EUR	EUR
Hebrew	ILS, USD, EUR	ILS
Italian	USD, RUB, EUR, GBP, CHF	EUR
Mandarin Chinese	USD, CNY	USD
Myanmar	USD, EUR, THB, MMK	MMK
Portuguese	USD, BRL, EUR	EUR
Russian	USD, RUB	RUB
Spanish	USD, EUR, CRC	EUR
Swedish	SEK, USD, RUB, EUR, GBP, THB, INR, MYR, BND, AED, IRR	USD
Swiss French	USD, EUR, FRF	USD

**ISO 4217 code**

**AED** – United Arab Emirates dirham  
**AUD** – Australian dollar  
**BDT** – Bangladeshi taka  
**BHD** – Bahraini dinar  
**BND** – Brunei dollar  
**BRL** – Brazilian real  
**CHF** – Swiss franc  
**CNY** – Renminbi  
**CRC** – Costa Rican colón  
**DKK** – Danish krone  
**EGP** – Egyptian pound  
**EUR** – Euro  
**FRF** – French franc  
**GBP** – Pound sterling  
**HKD** – Hong Kong dollar  
**IDR** – Indonesian rupiah  
**ILS** – Israeli new shekel

**INR** – Indian rupee  
**IQD** – Iraqi dinar  
**IRR** – Iranian rial  
**JOD** – Jordanian dinar  
**MMK** – Burmese kyat  
**MXN** – Mexican peso  
**MYR** – Malaysian ringgit  
**NGN** – Nigerian naira  
**NZD** – New Zealand dollar  
**PHP** – Philippine peso  
**PKR** – Pakistani rupee  
**RUB** – Russian ruble  
**SEK** – Swedish krona  
**SGD** – Singapore dollar  
**THB** – Thai baht  
**TRY** – Turkish lira  
**USD** – United States dollar  
**ZAR** – South African rand

## APPENDIX F. IVR Flow Diagrams

### One's Own Voice Mailbox Access IVR (Short Schema)

The Media Server mailbox can be accessed by phone by dialing \*98.

Below is an IVR path diagram to help users in navigating and configuring the system. A full IVR diagram can be found in the [One's Own Voice Mailbox Access IVR \(Full Schema\)](#) section.

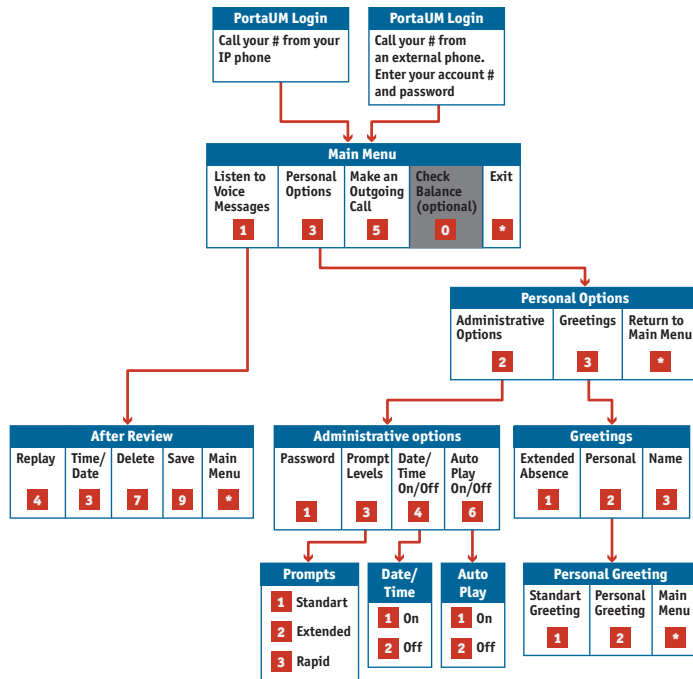

### Account Self-care IVR (Short Schema)

Below is a brief IVR path diagram to help users to navigate and configure the system. A full IVR diagram can be found in the [Account Self-care IVR \(Full Schema\)](#) section.

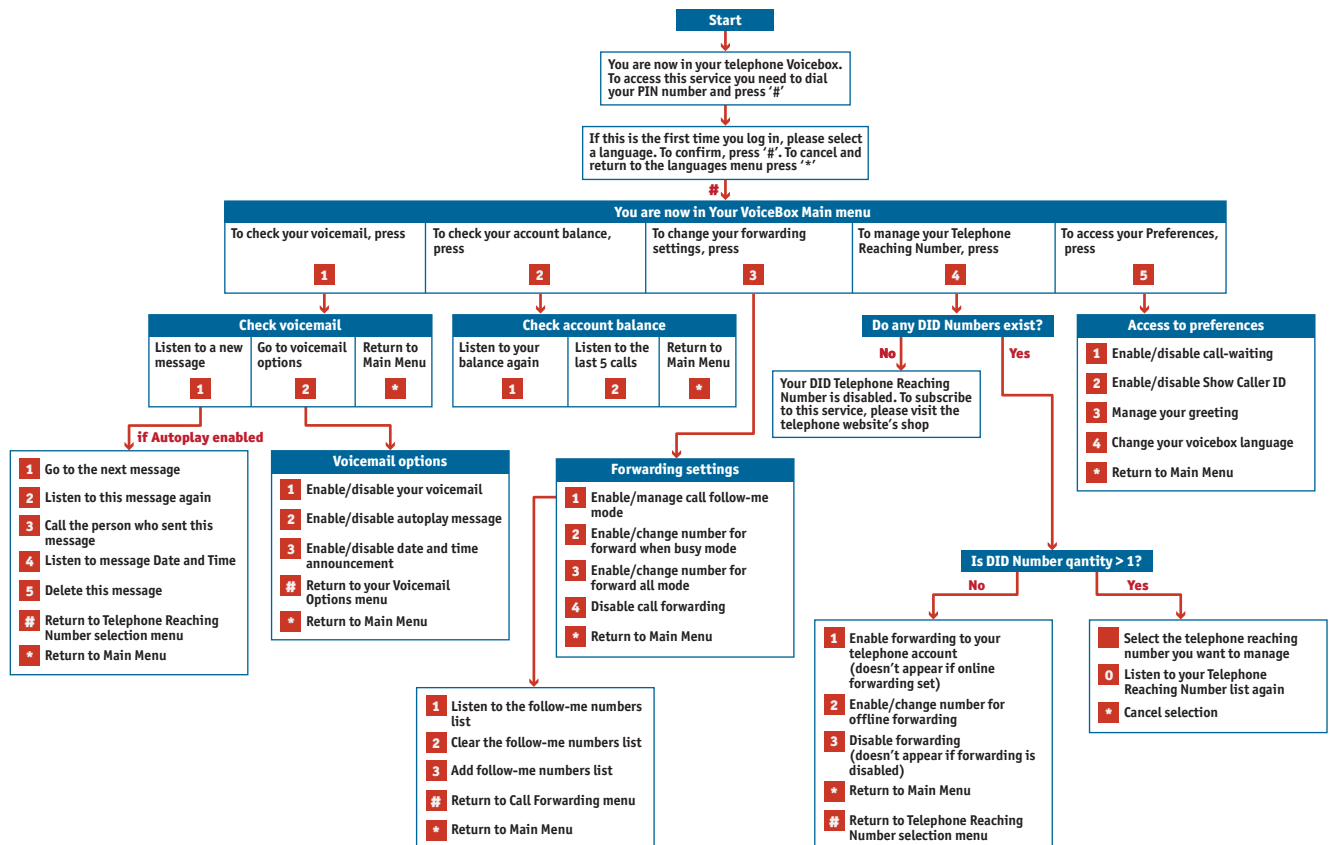

Account Top-up via Voucher IVR

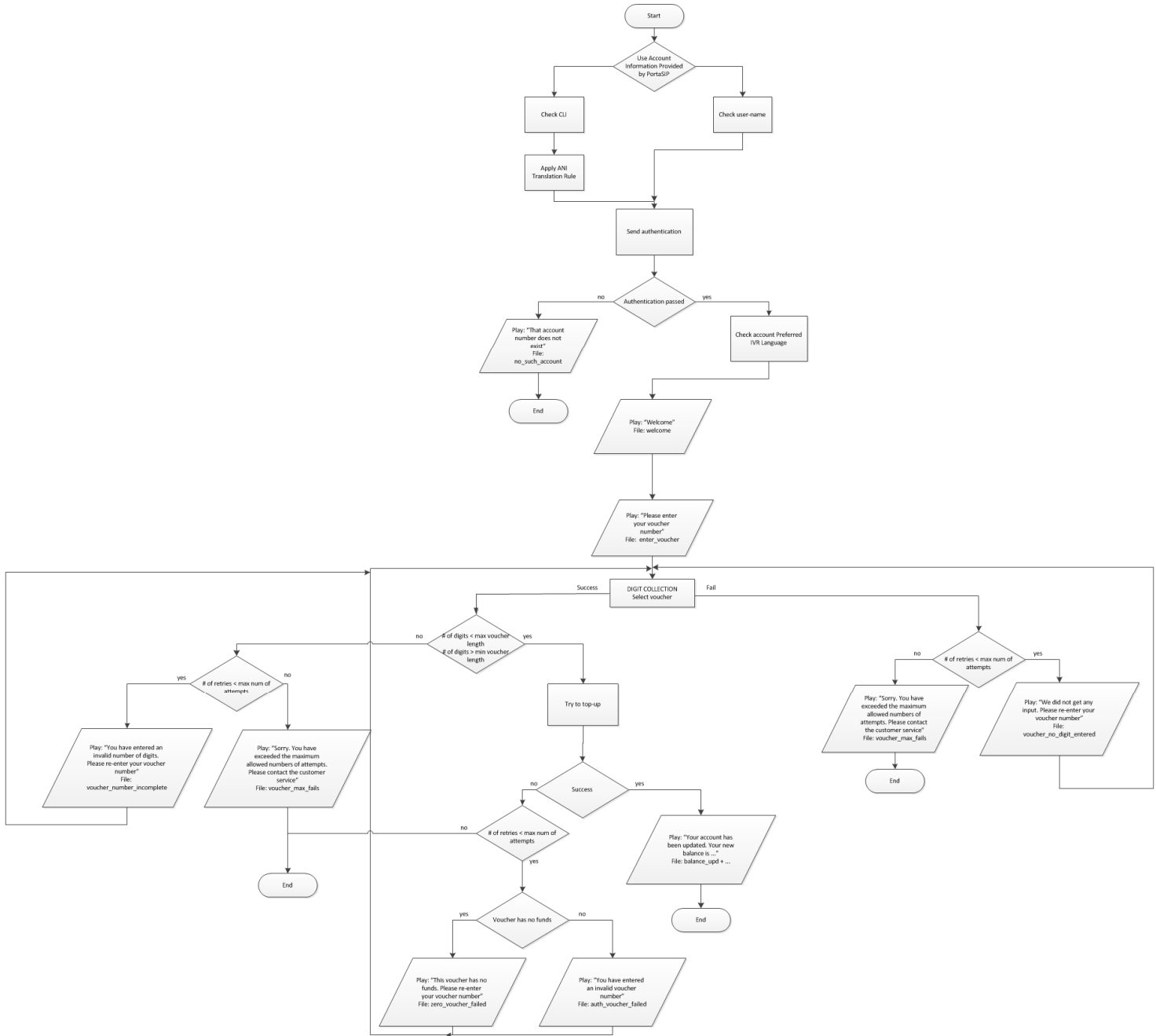

Account Top-up via Credit Card IVR

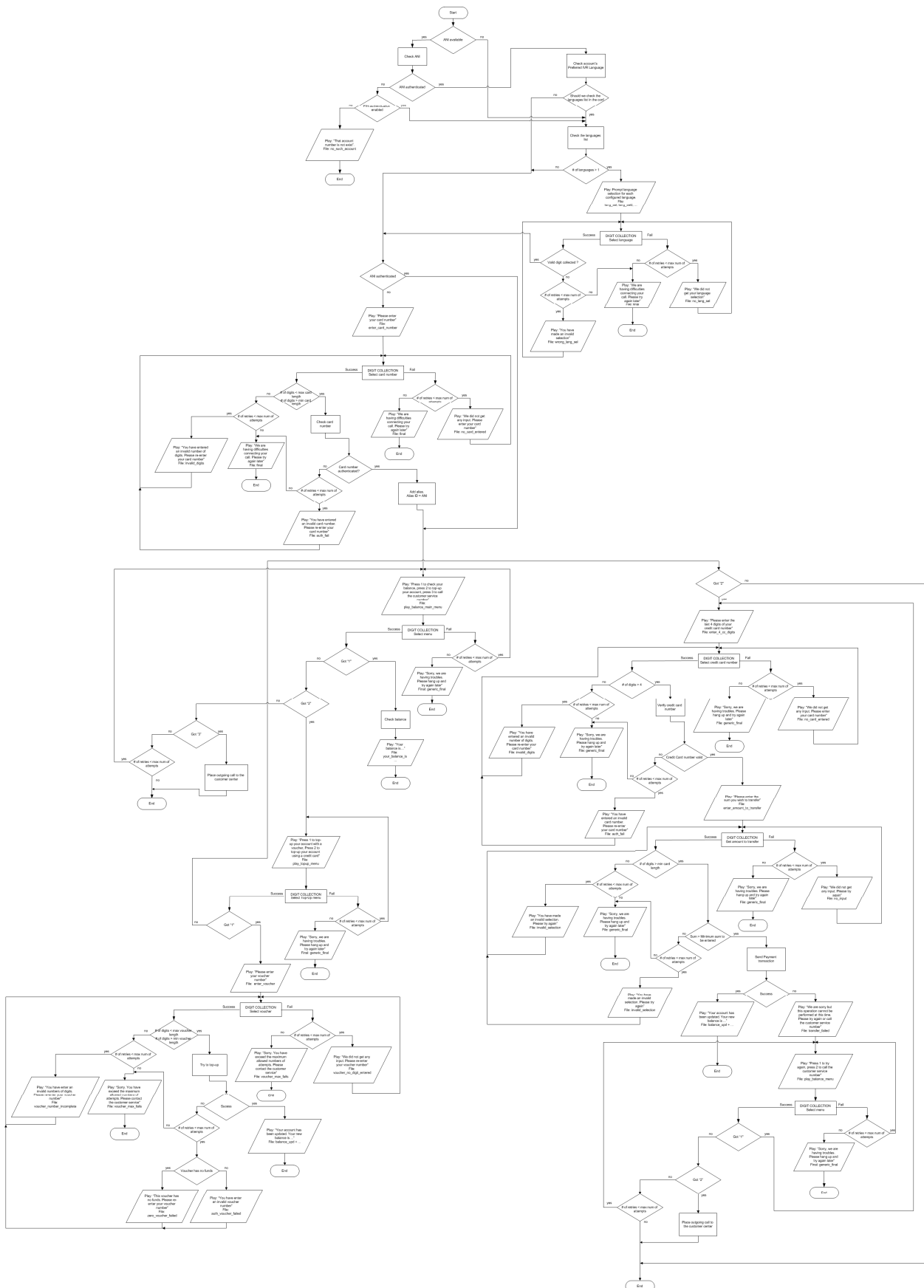

### Balance Information





### Simplified Account Self-care IVR

**Application note.**  
The DNIS format should be:  
\*77\*pin\*123456789  
where \*77 - Account Management IVR DNIS;  
n - operation (1 - recharge account, 2 - add alias, 3 - delete alias);  
123456789 - passed Alias ID or Voucher ID

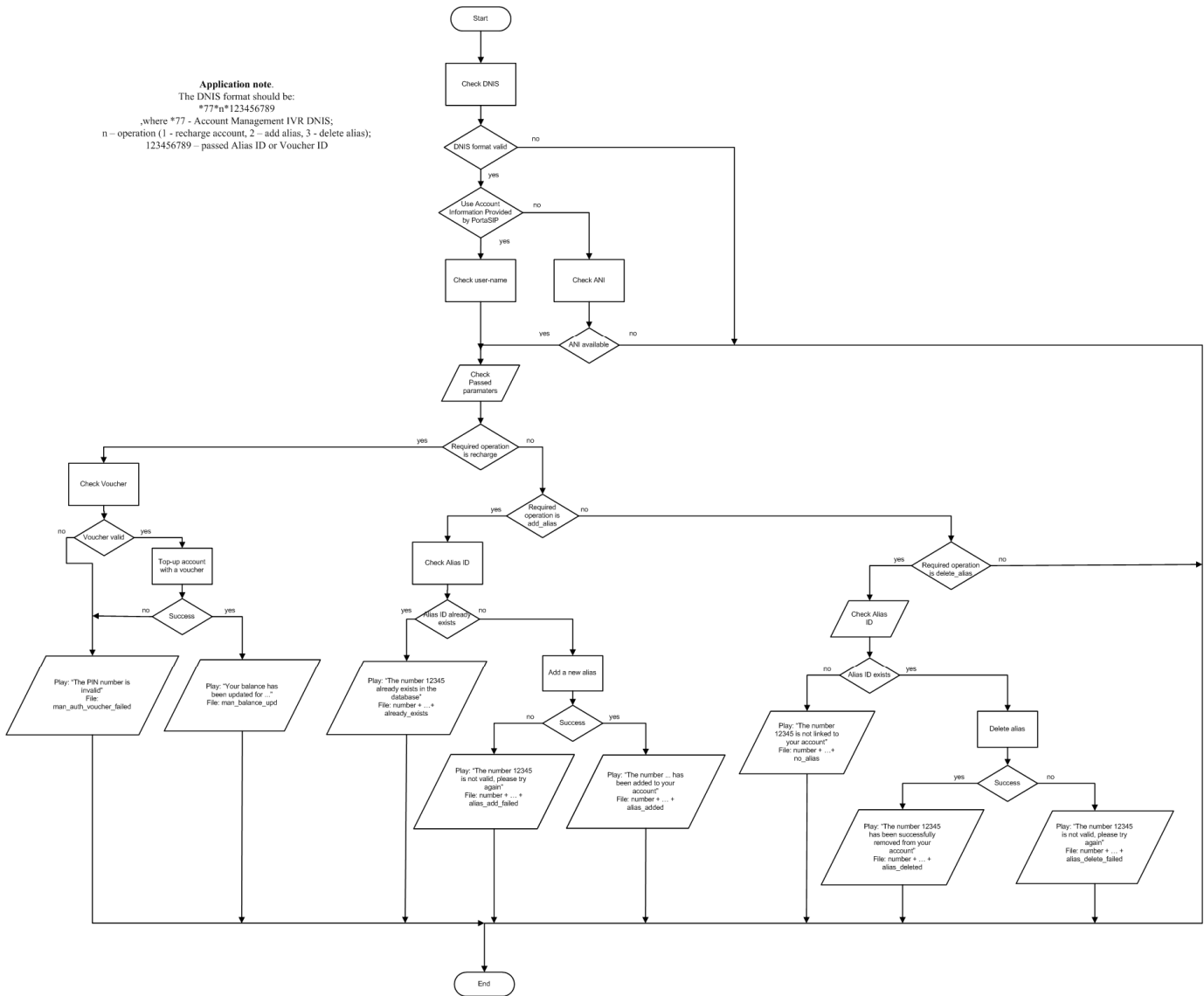

### Call Forwarding Management IVR

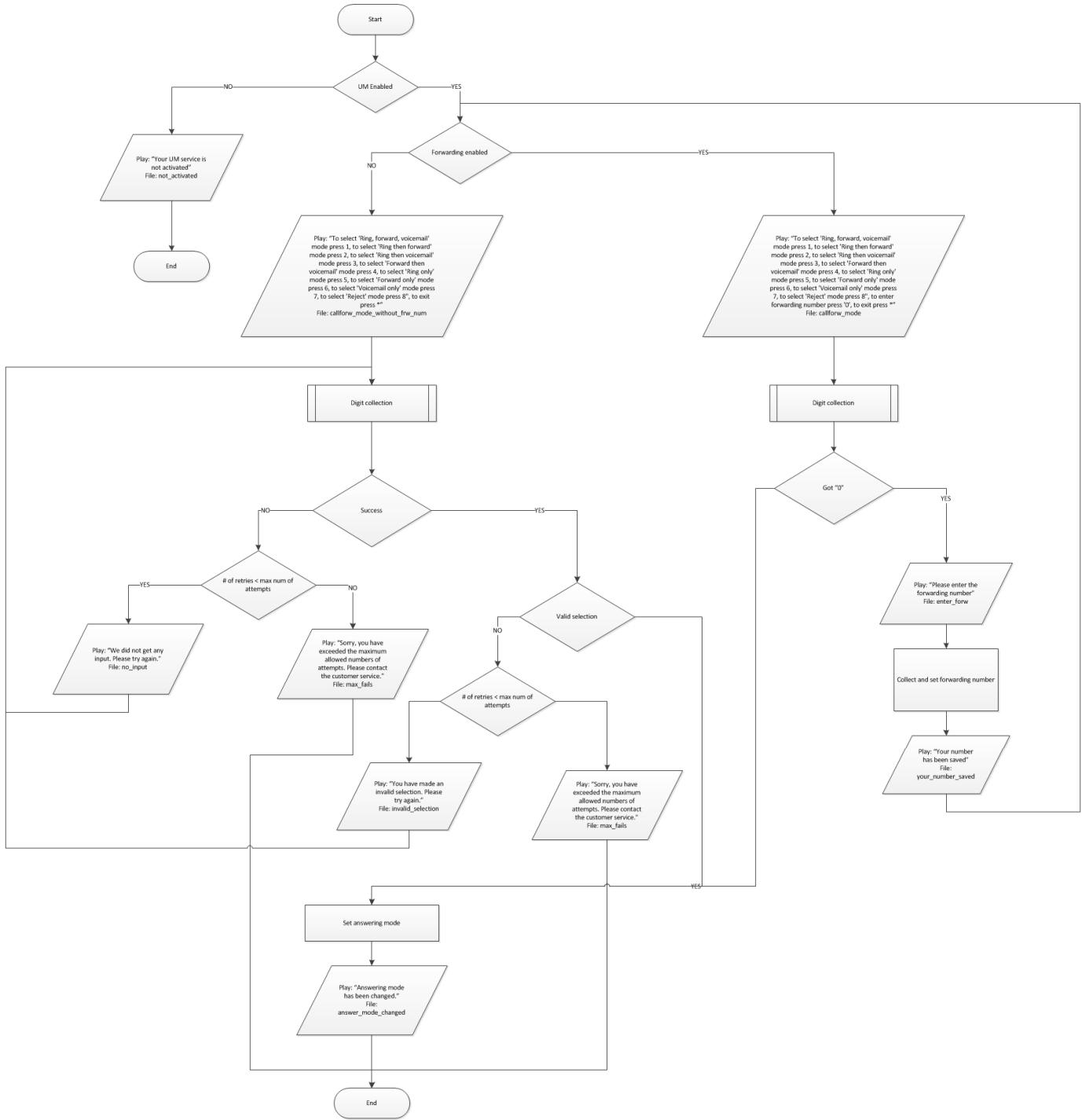

### Prepaid Card Calling IVR

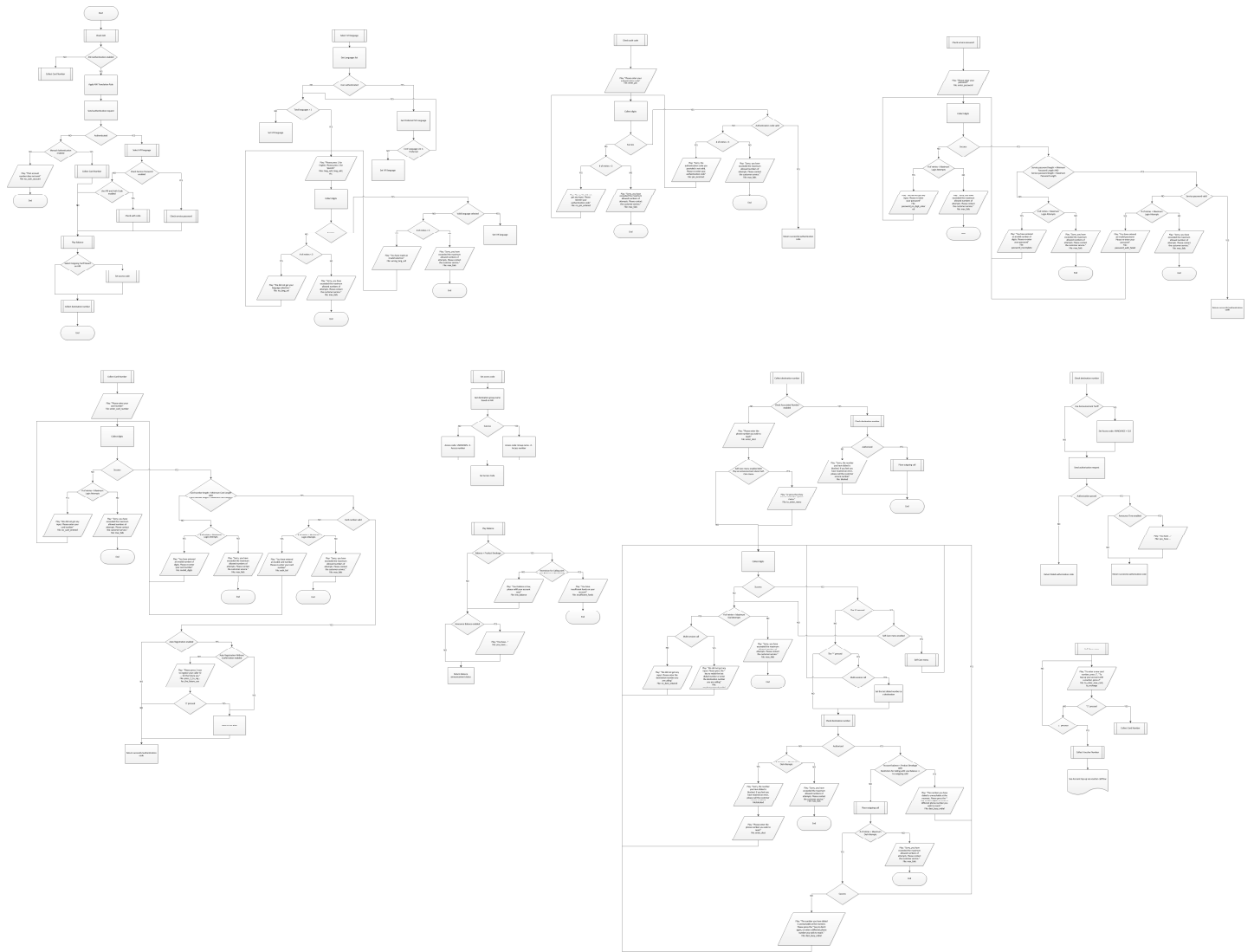

## Callback IVRs

### ANI Callback IVR Part 1

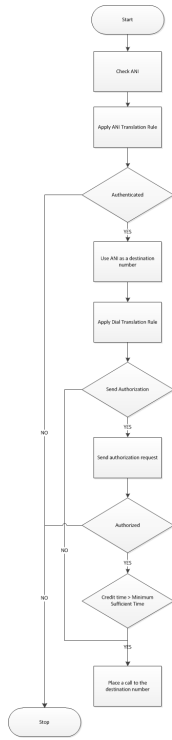

### ANI Callback IVR Part 2

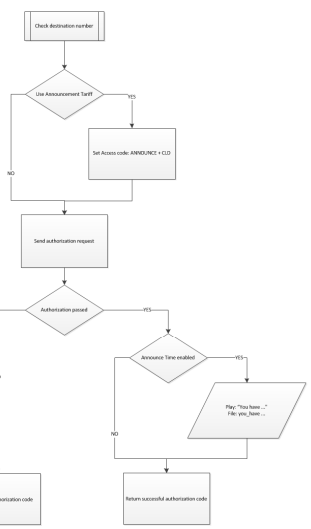
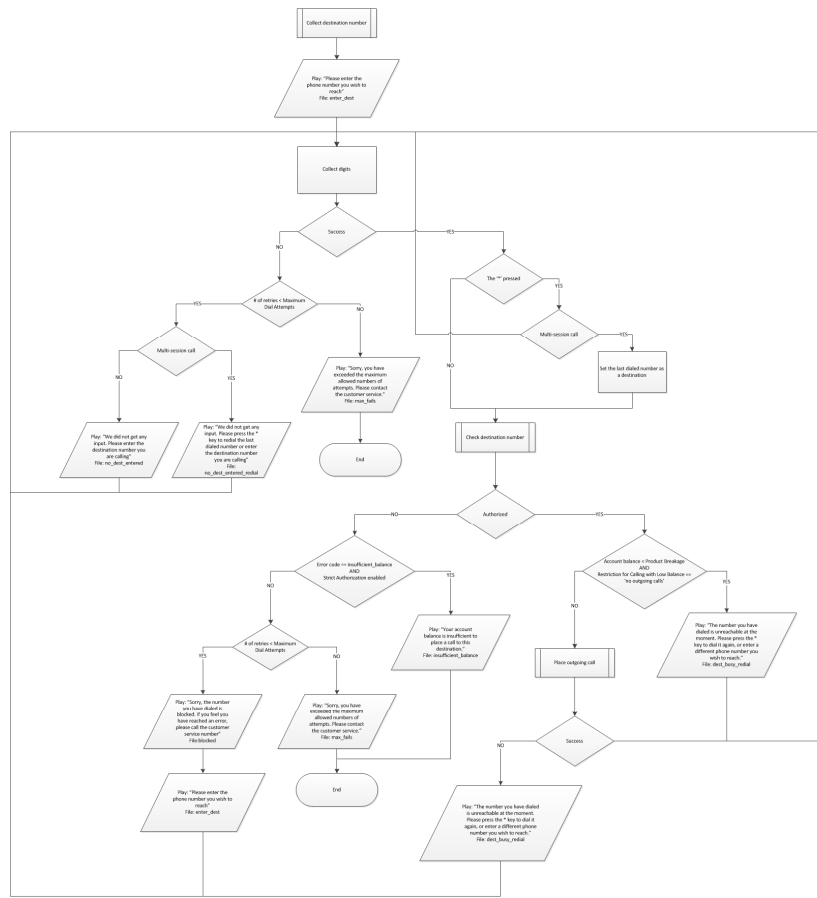
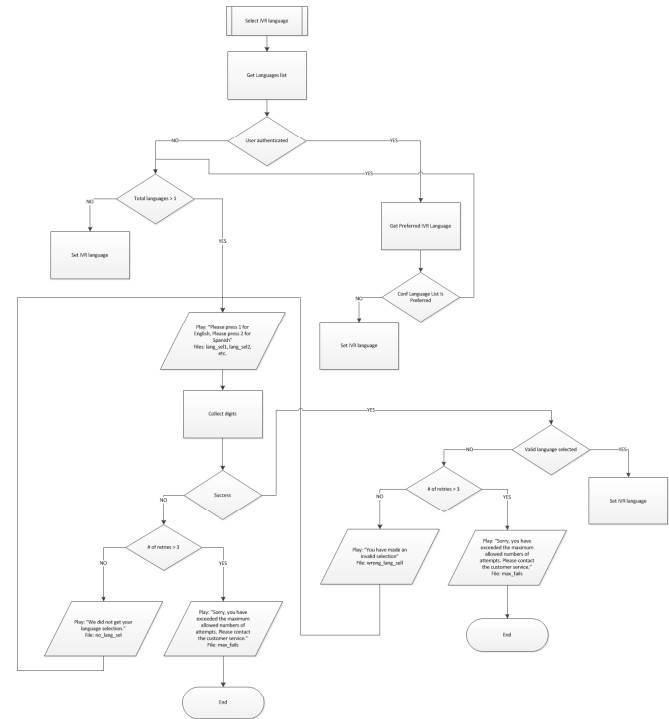
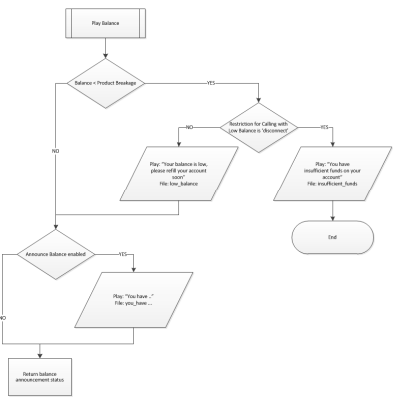
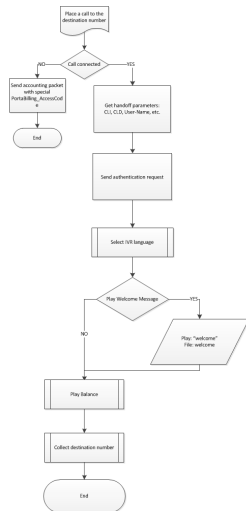

DNIS Callback IVR Part 1

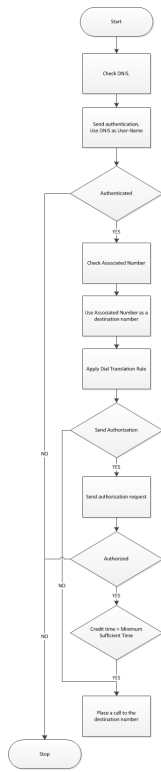

DNIS Callback IVR Part 2

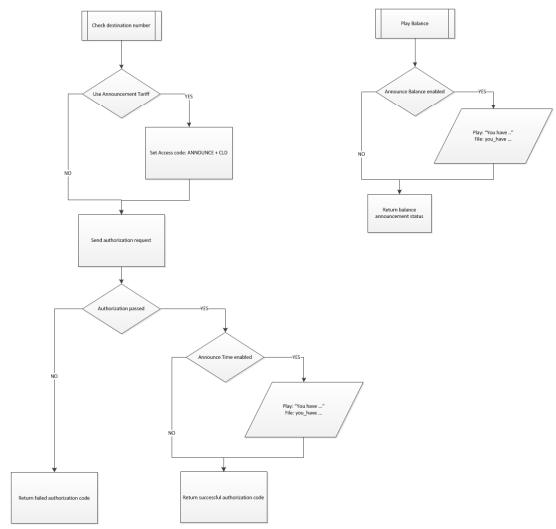
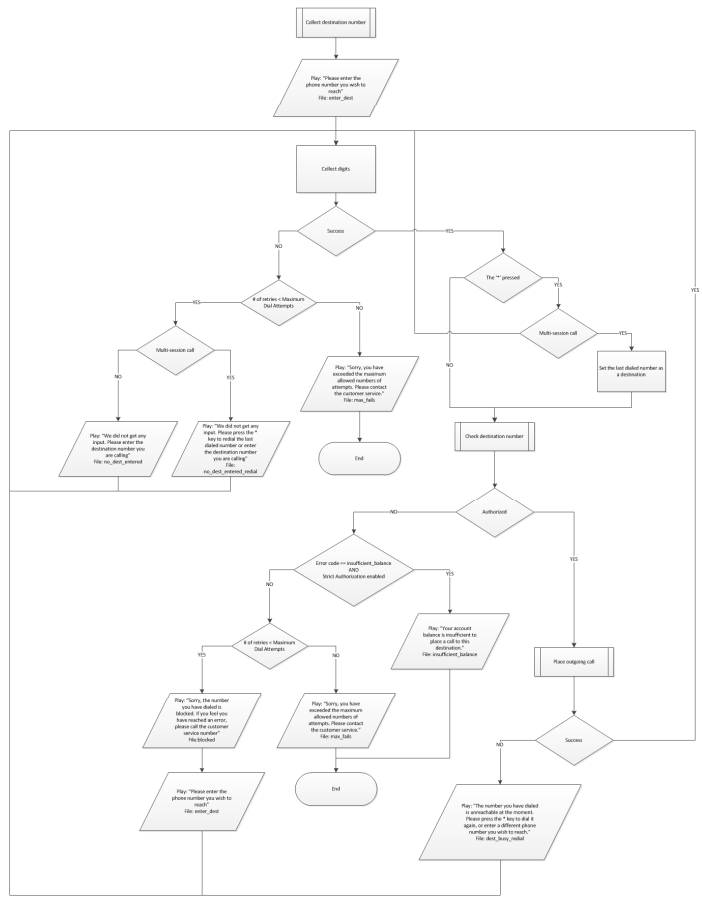
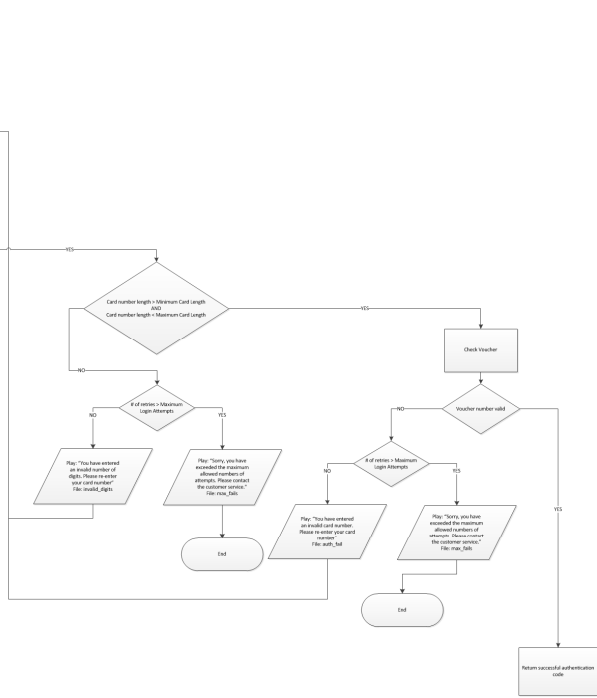
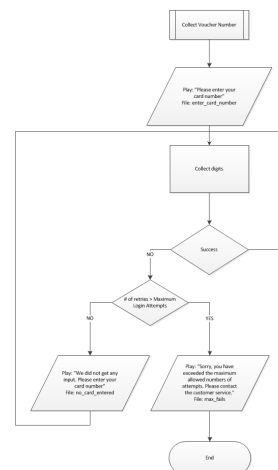
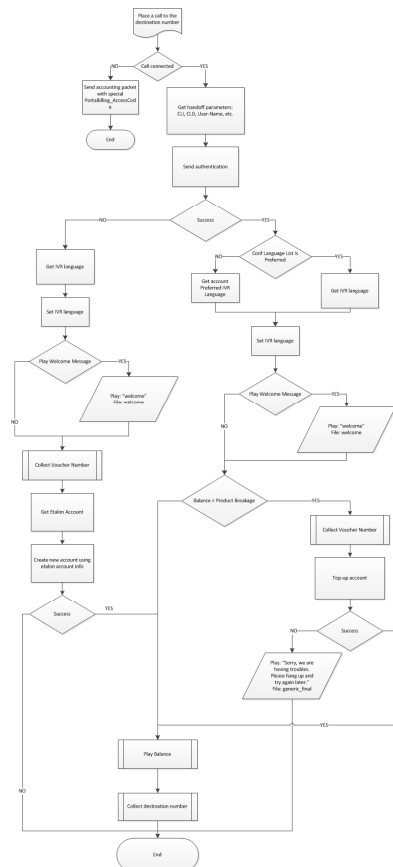

### PIN Callback IVR Part 1

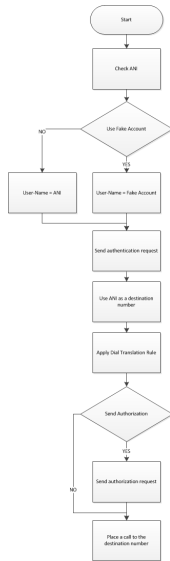

### PIN Callback IVR Part 2



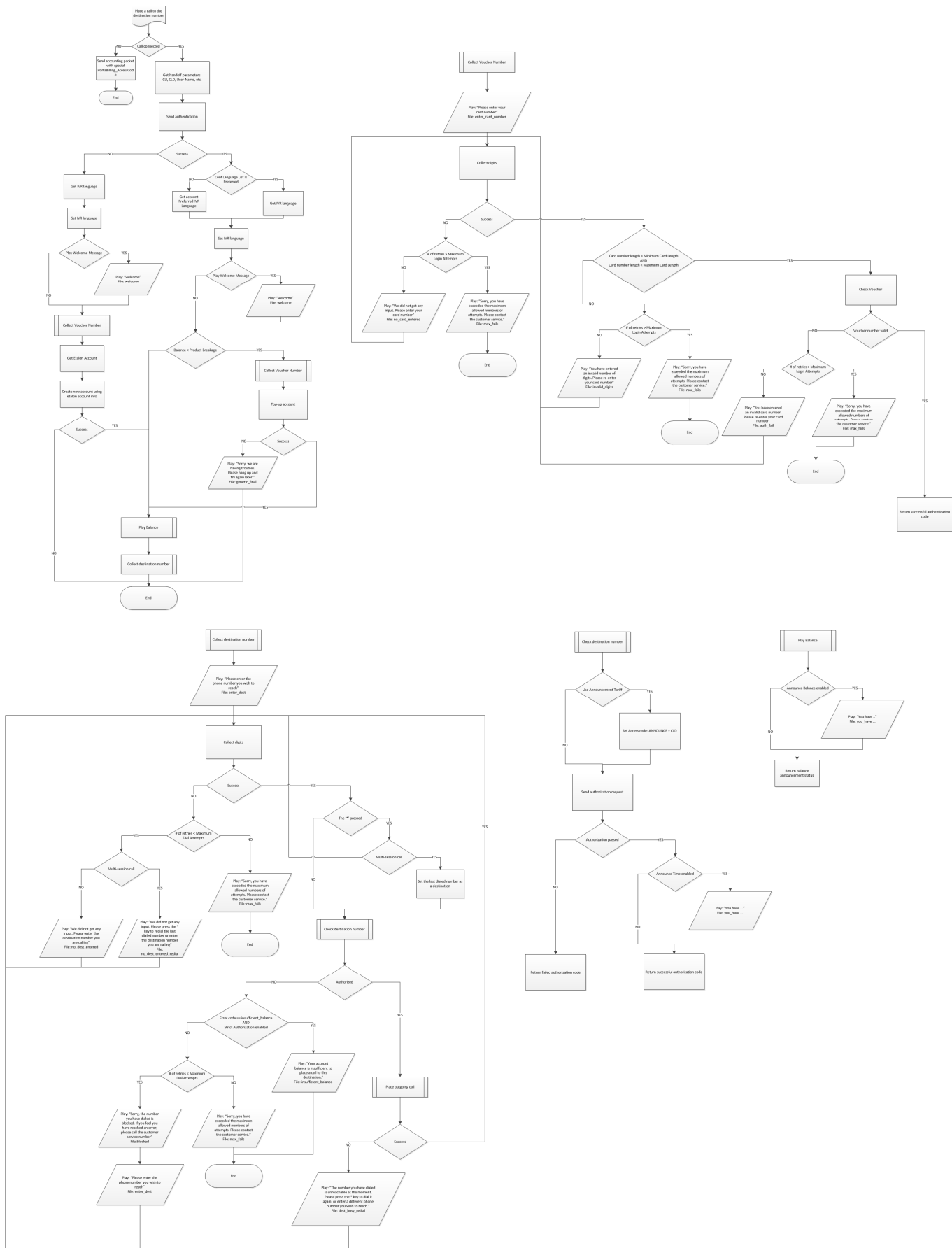

Callback with Registration IVR Part 1

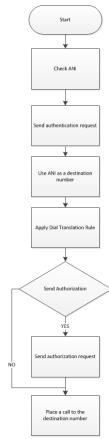

Callback with Registration IVR Part 2

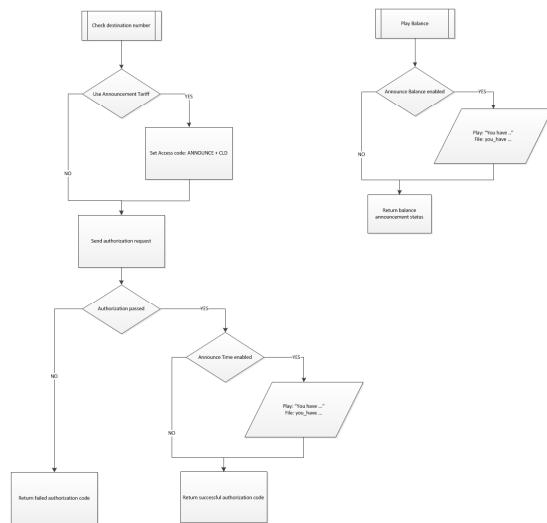
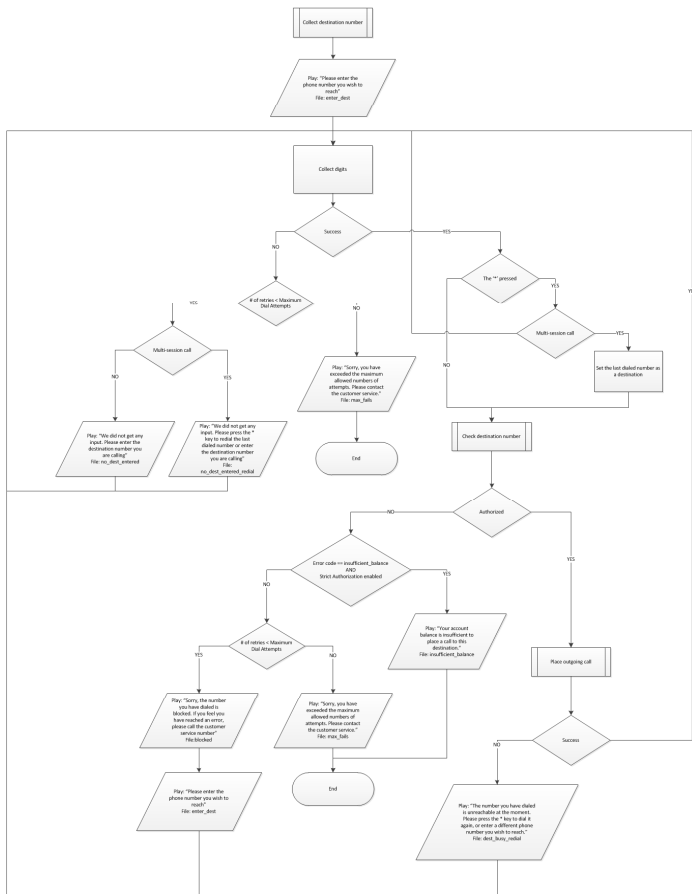
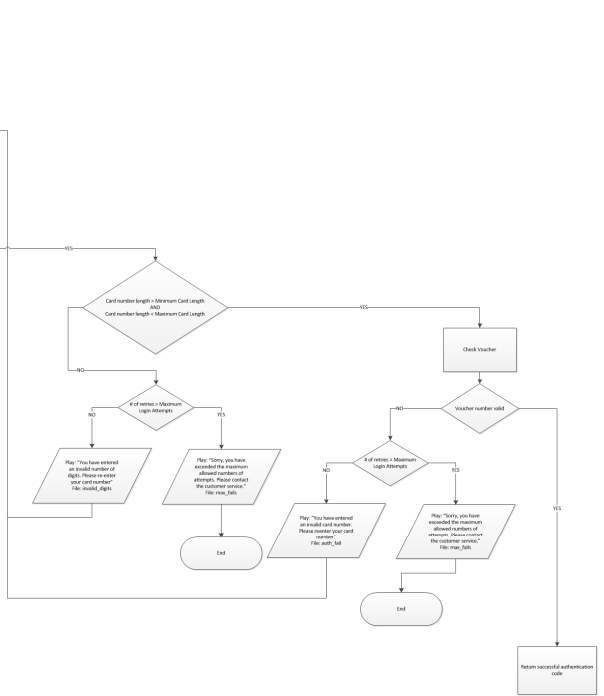
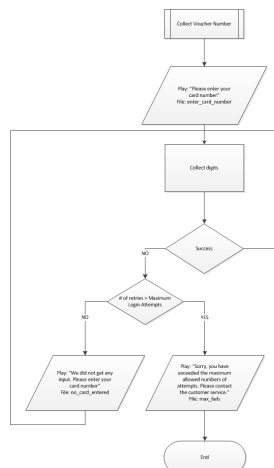
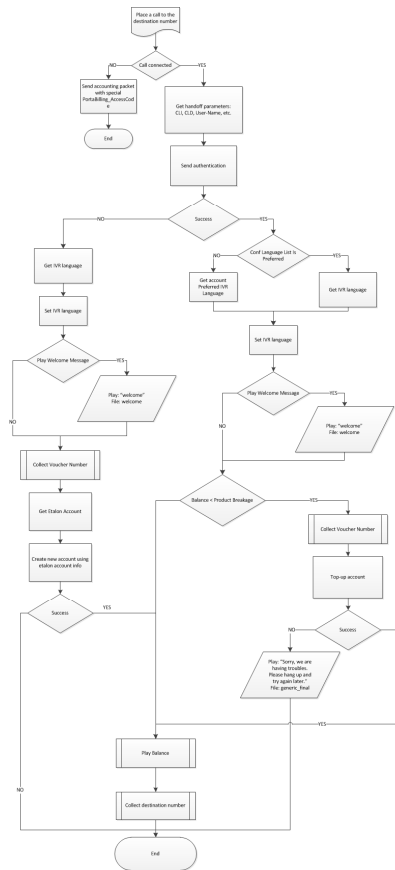

Premium Numbers IVR

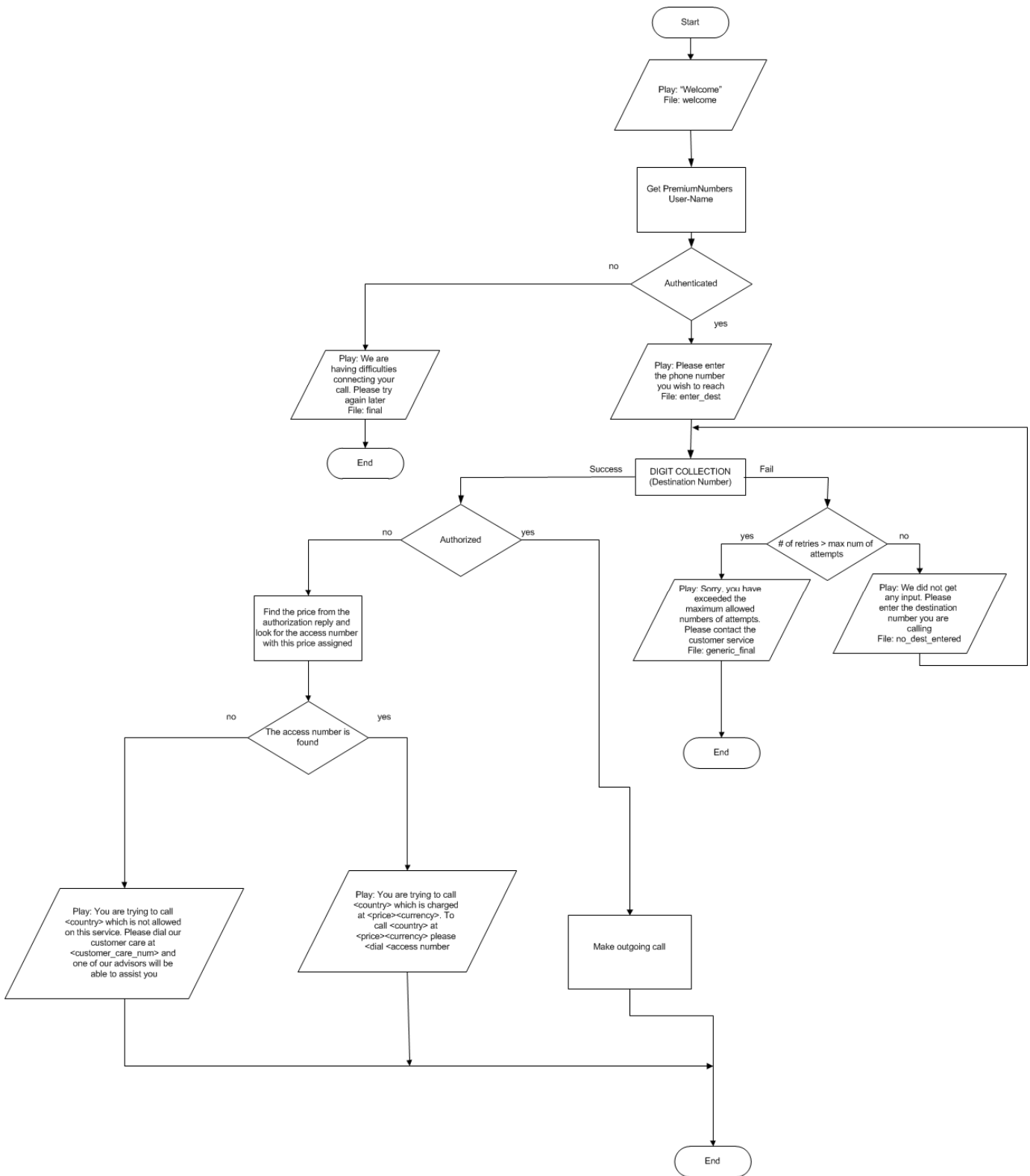

One-stage Calling IVR

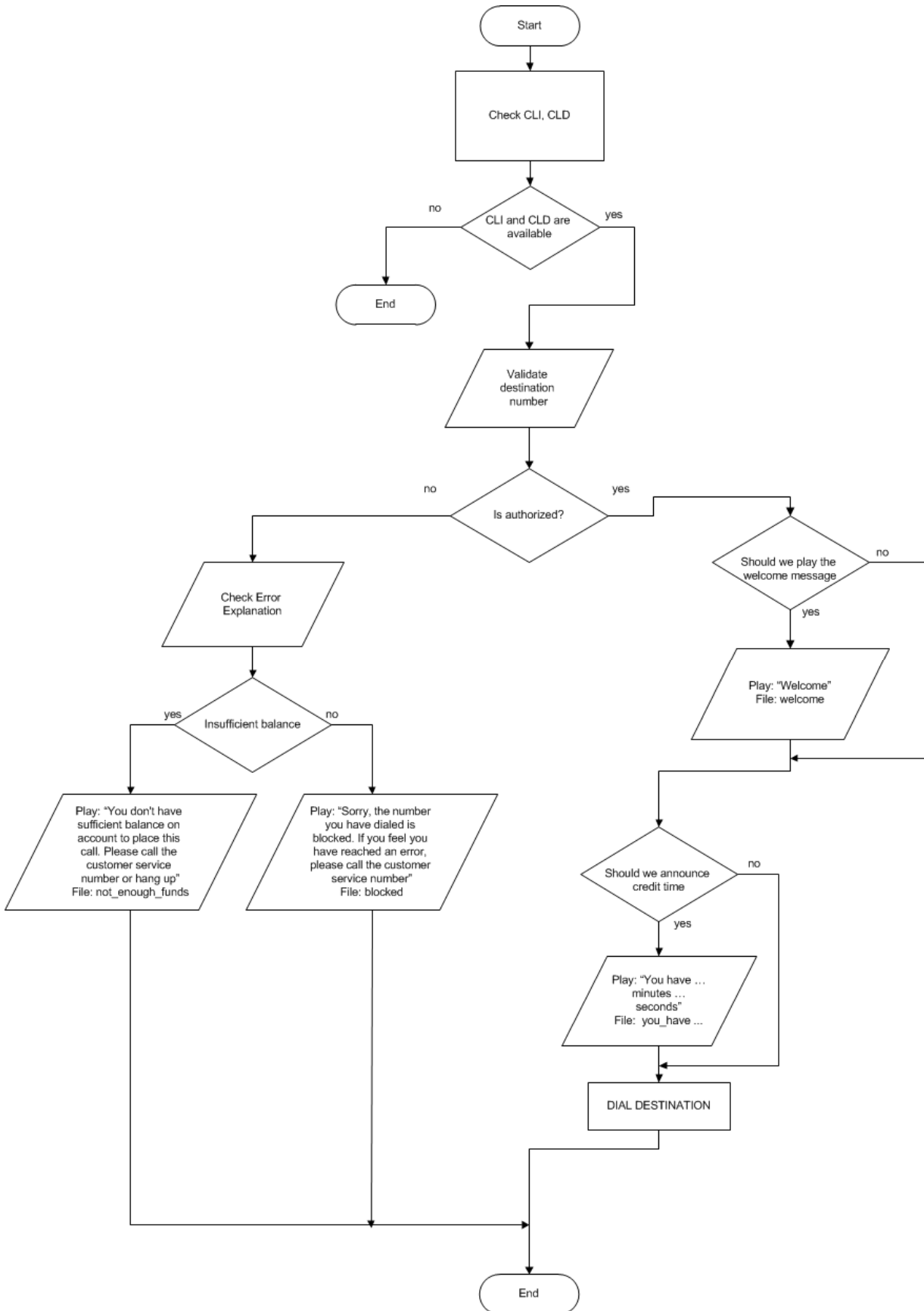

Payment Remittance - TransferTo IVR

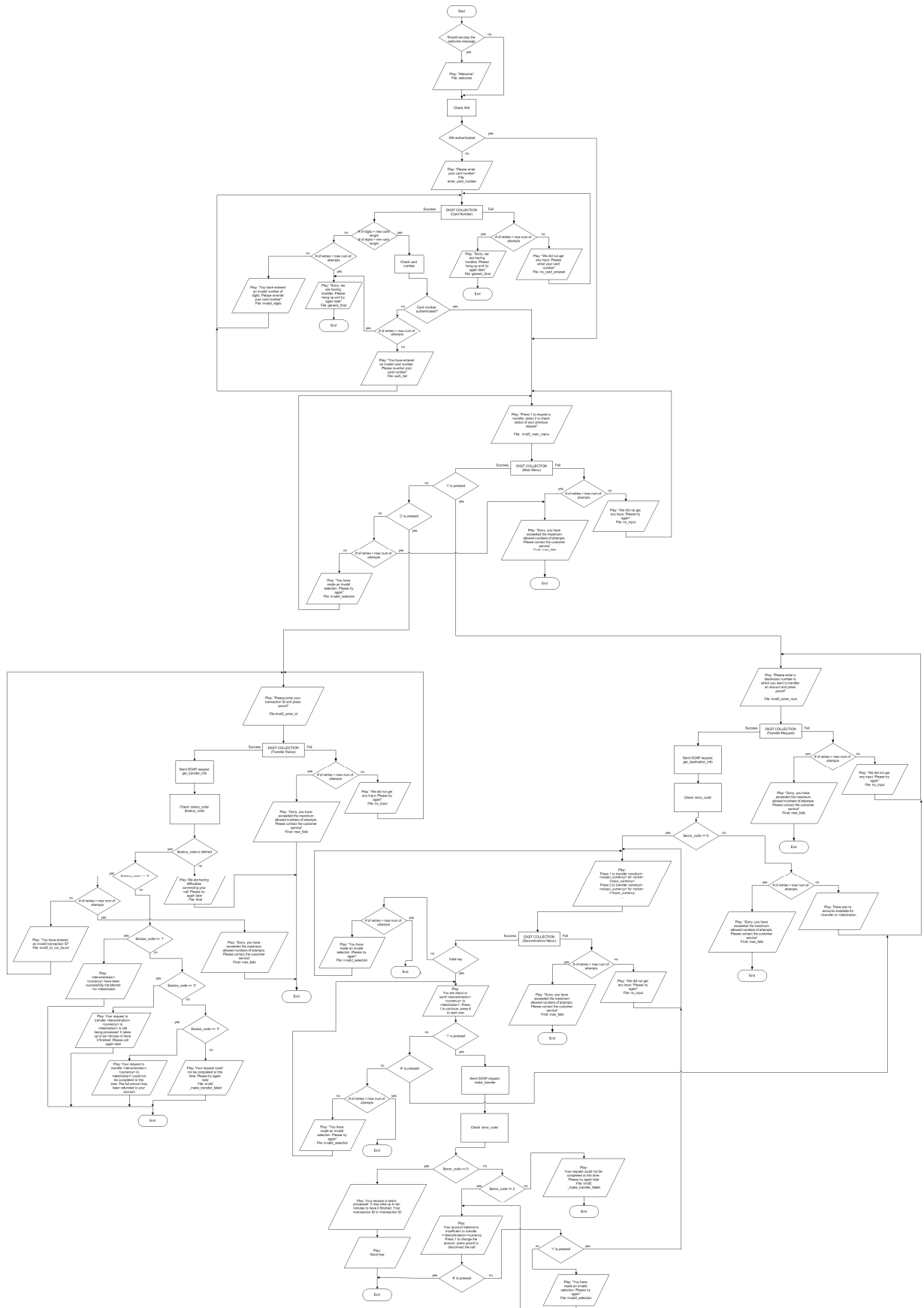

Holiday Line Management

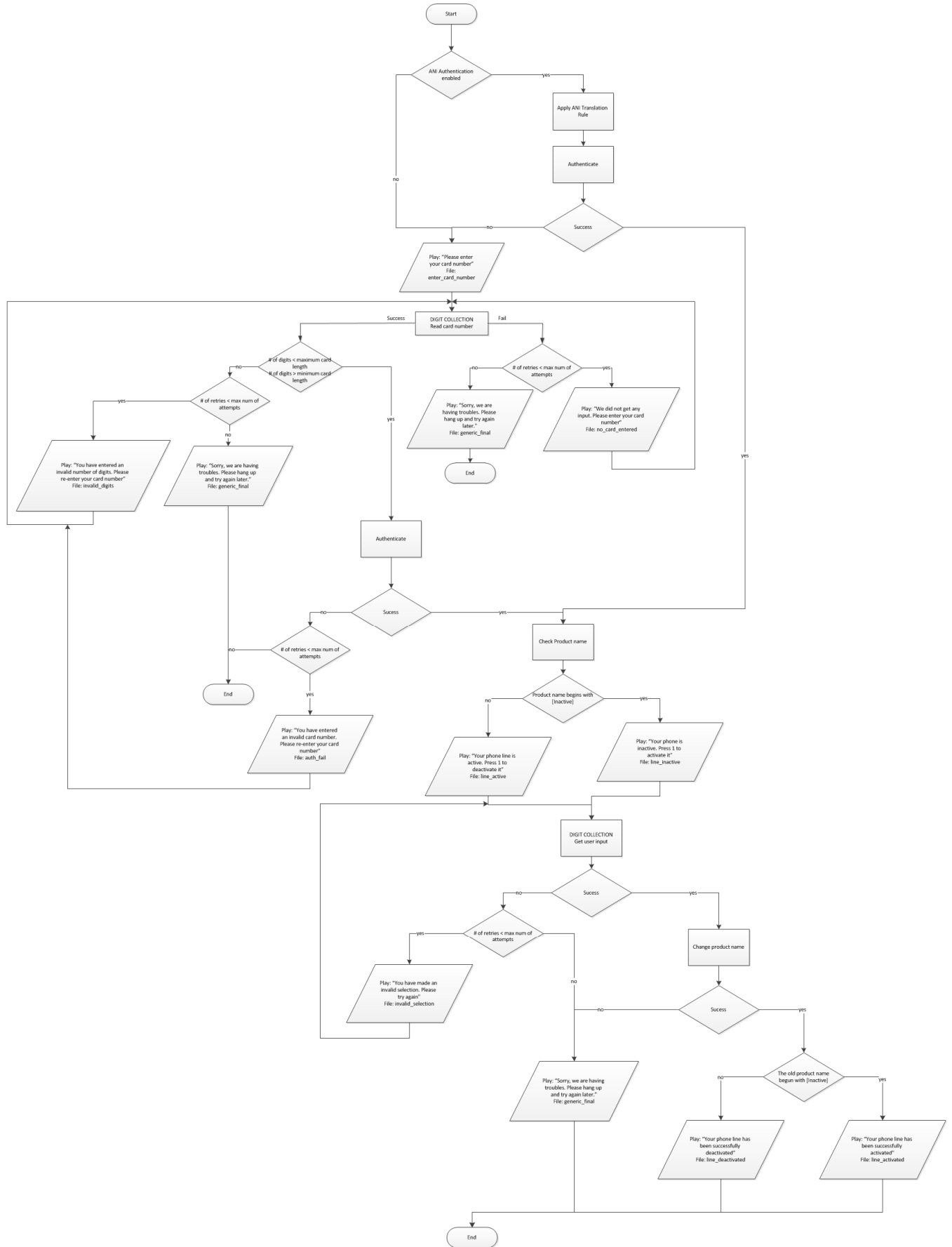

Pass-Through IVR

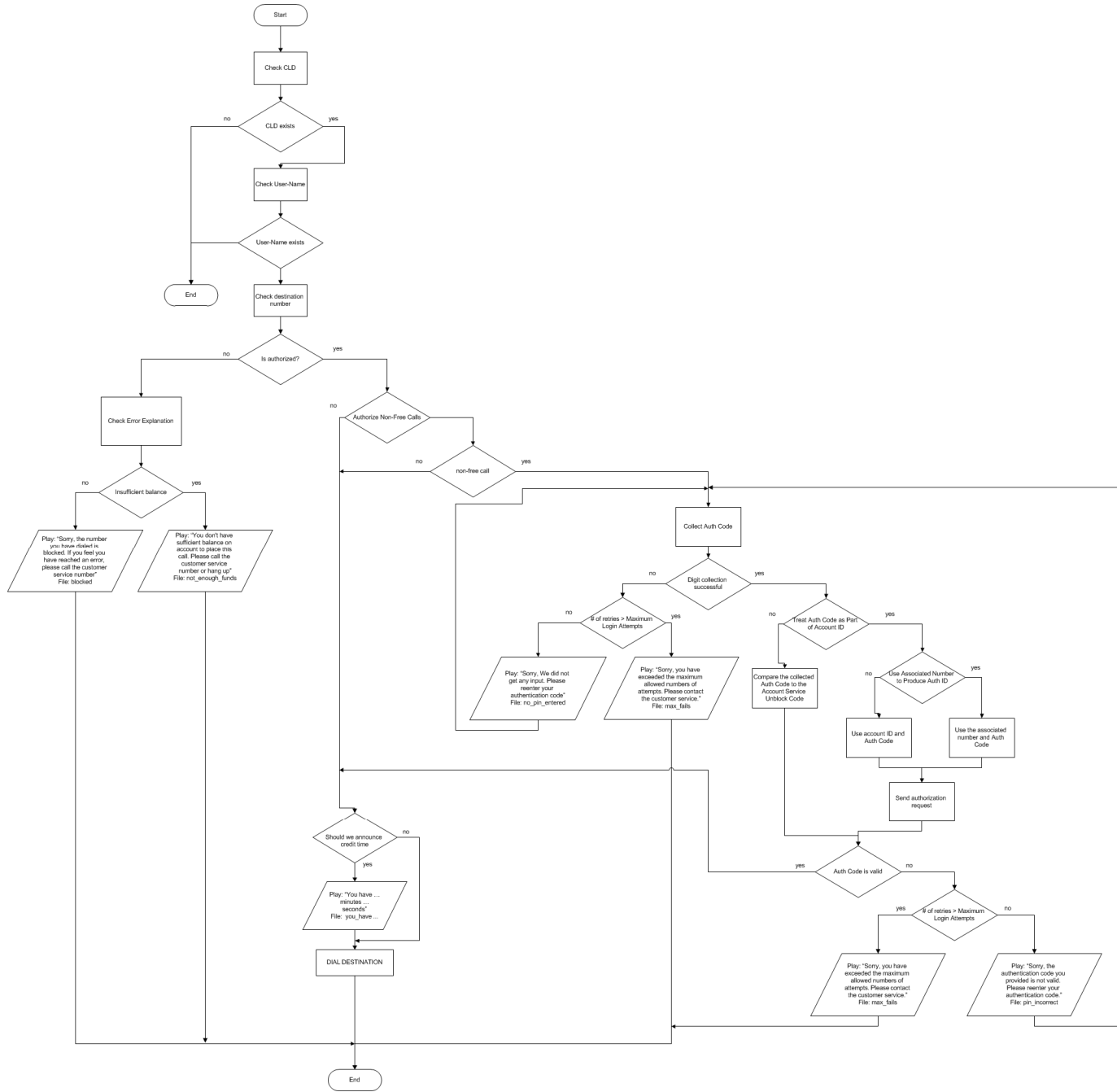



### Conferencing IVR

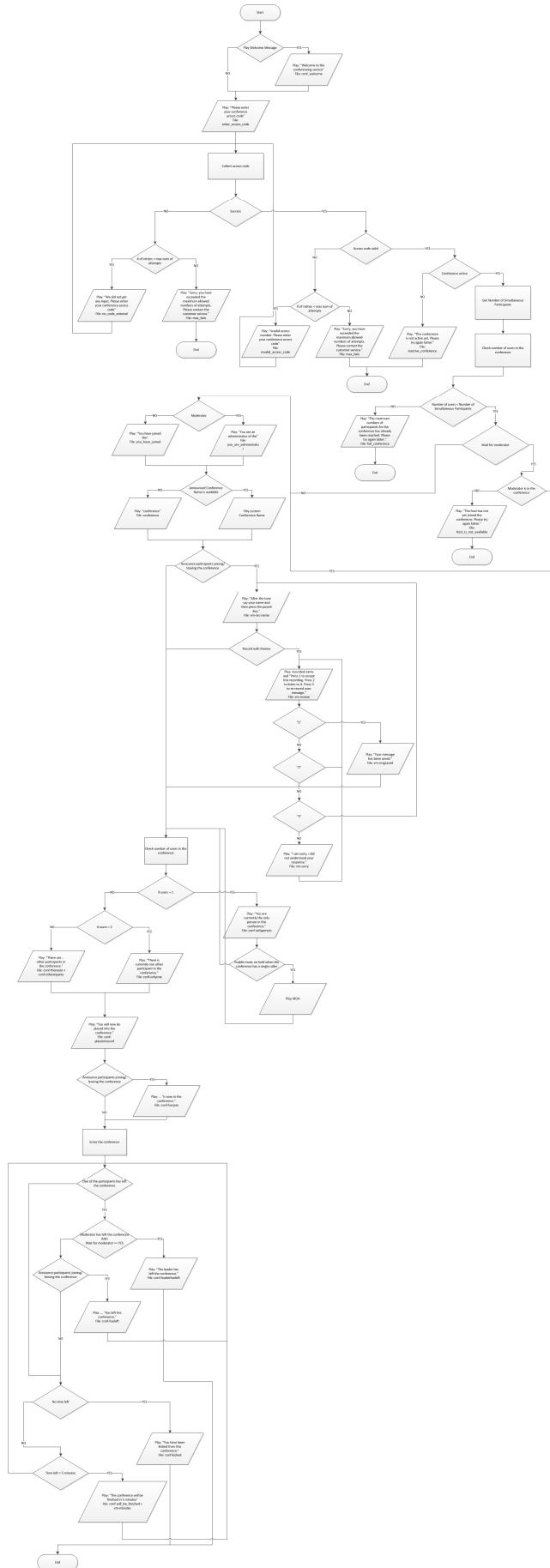

### One's Own Voice Mailbox Access IVR (Full Schema)

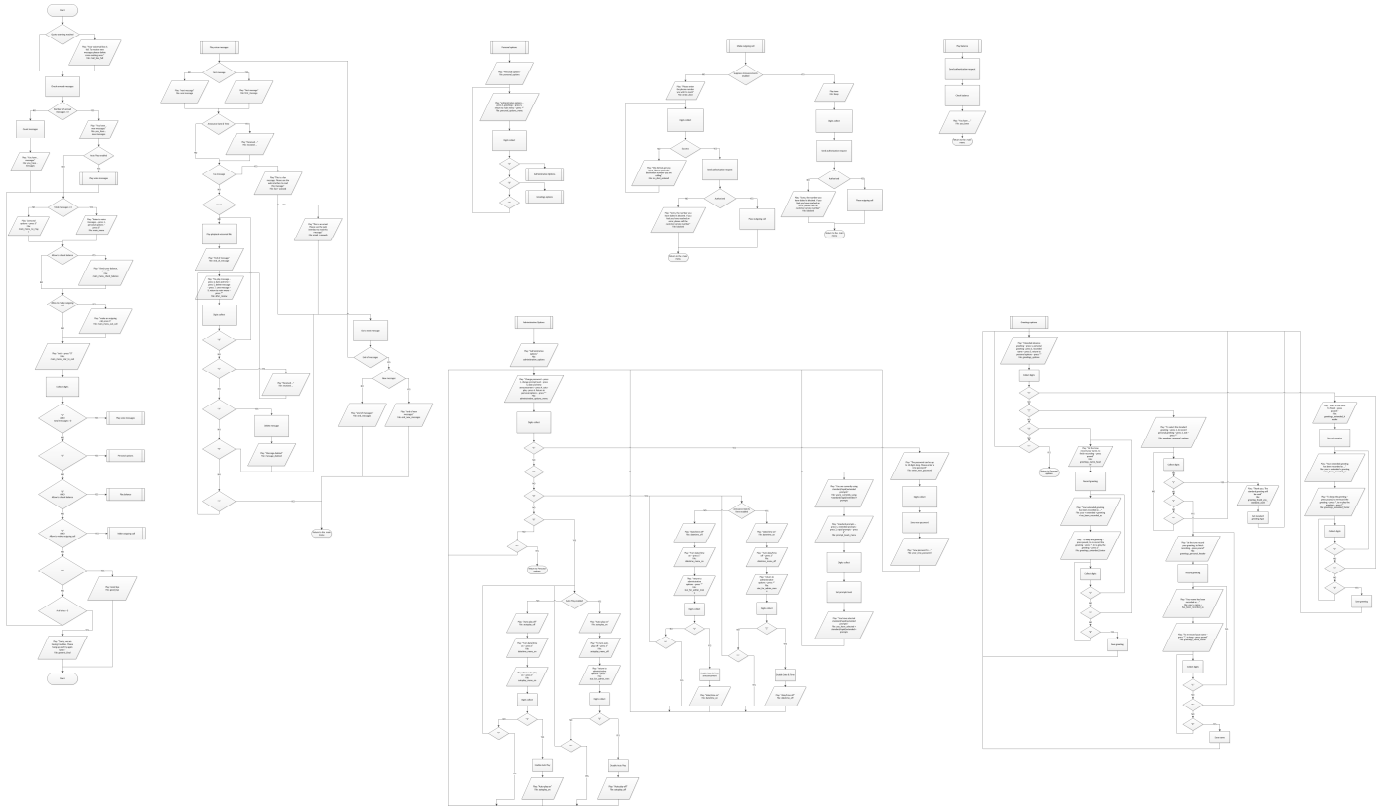

### Account Self-care IVR (Full Schema)

